

BALMAR

WWW.BALMAR.NET

MAX CHARGE MC-612-DUAL MULTI-STAGE VOLTAGE REGULATOR WITH DUAL FIELD OUTPUT

BALLARD COMMERCIAL INDUSTRIES, INC.
18930 59TH AVE., NE, ARLINGTON, WA 98223
ON THE INTERNET: WWW.BALMAR.NET
© COPYRIGHT 2009, REVISED 8-23-2011



INSTALLATION AND OPERATION MANUAL

Introduction

The Balmar Max Charge MC-612-DUAL is designed for use in single engine / dual alternator applications where both alternators are being used to charge the same large battery bank.

The MC-612-DUAL provides two field output connectors, two power input connectors and two system ground connections, making it possible to use two standard wiring harnesses when connecting to two alternators.

The MC-612-DUAL features selectable preset programs for standard flooded, deep cycle flooded, Optima, gel, and AGM batteries, as well as a universal factory program for all battery types and a special program for halogen systems. In addition, the MC-612-DUAL offers a broad range of advanced programming features described later in this manual.

When used in conjunction with optional alternator and battery temperature sensors, the MC-612-DUAL has the ability to monitor temperatures and respond by increasing or decreasing voltage output to adapt to conditions. By selecting the setting that best suits the application, the user can provide sensing at two alternators and one battery bank or one alternator and two battery banks. To take the best advantage of the MC-612-DUAL and its features, please take the time to read this manual.

Safety Considerations

1. Always disconnect your battery banks and ensure that switches are "OFF" prior to installing your regulator.
2. Remove loose-fitting clothing or jewelry, which could become entangled in your motor or other machinery prior to installing regulator.
3. Wear ANSI-approved safety eye-wear and protective gear.
4. DO NOT attempt to modify the regulator. Modifications could result in damage to your charging system, and will void your warranty.
5. Do not attempt installation if you are tired or fatigued.
6. Ensure that the engine has cooled before initiating installation.
7. Do not attempt regulator installation while using alcohol or medication that could impair your judgment or reaction time.
8. Always use the right tool for the job. Improper tool use may damage regulator or your vessel, and could result in personal injury.
9. Take time to read the manual. Equipment damage and possible injuries may result from an incomplete understanding of the installation and operation of the MC-612 regulator. If you are unfamiliar with marine electrical systems, consult with a licensed marine electrician.

Introduction.....	1	Basic Programming.....	9
Safety Considerations.....	1	Adjust For Battery Type	9
Regulator Installation.....	2	Belt Load Manager	10
Unpacking Box	2	Toggle #2 ALT/BAT Sense..	10
Locate/Mount Regulator	2	Advanced Programming	11
Basic Wiring Installation.....	2	Unlock Adv. Programming.	11
Regulator Terminal Layout ..	3	Adjust Adv. Programs	11-12
Installation By Wire	4-6	Default Program Settings ..	12
Initial Start Up	6	Add'l. Regulator Features..	13
Regulator Operation.....	7	Troubleshooting	13-15
Regulator Display Modes.....	8	System Wiring Diagram	16
Using Magnetic Tool.....	9	Warranty	16
Regulator Programming	9		

CAUTION: The Balmar Max Charge MC-612-DUAL is designed for use in single engine, dual alternator applications where both alternators are being used to charge the same large battery bank. The following instructions are intended for use by experienced marine electrical installers. If you are not experienced at installing electrical system components, we recommend the use of a qualified marine electrical technician.

Regulator Installation

The following information is intended to provide the installer with the basic information required to complete installation. This section of the installation manual will deal with mounting, wiring connections and basic programming for battery type. Additional information regarding advanced programming adjustments and troubleshooting are addressed later in the manual.

Unpacking The Box

Your Max Charge MC-612-DUAL-H regulator kit is packaged with the following items:

- Max Charge MC-612-DUAL regulator
- (2) 54" wiring harnesses w/ 10A-fused 12 Ga. RED power wires
- Fused (1A) battery sense wire pigtail
- Magnetic programming tool
- Installation and operation manual

If any of the listed items is not included with your regulator kit, call our customer service department at 360-435-6100. Please note -- if your regulator box is marked Max Charge MC-612, without the "H" designation, your kit will not include the wiring harnesses or fused battery sense pigtail.

Locate And Mount The Regulator

Choosing a mounting location for your voltage regulator should be determined based on the following factors; distance from alternator, distance from inverters, transmitters and other sources of RF noise, convenient access and readability of the display. The regulator wiring harness is 54 inches long, providing a three to four foot radius for mounting. Ample airflow is essential for the regulator's proper operation. Ensure that the regulator is free from obstructions that restrict air movement around or below the regulator's aluminum heat sink. While the regulator is designed to operate safely in conditions typical of a marine engine compartment, the regulator may be better protected, and easier to use and monitor if mounted outside of the engine compartment.

Should it be necessary to install the regulator further than the harness's 54" length from the alternator, ensure that any wire extensions are properly connected, as resistance in the harness wiring can affect charging efficiency. If harness length must reach beyond approximately eight feet, replace the RED power and BLUE field wires with larger gauge wire that's sized to ensure voltage drop < 3%..

Basic Wiring Installation

The regulator's wiring harness includes six wires required for standard installation. Four of those wires are connected to the regulator via a Ford-style plug connector that's pre-installed on the regulator. These wires include the Ground (BLACK), Power (RED), Ignition (BROWN) and Field (BLUE). Plug is shown at right.

In addition, the harness includes a separate Ground (BLACK) and Stator (WHITE) wire. The proper terminal connection points for these, and additional wiring connections, are illustrated on the pin location legend shown and discussed on the following pages.

The MC-612-DUAL is designed with parallel terminal locations for field, power and ground circuits, so two standard Balmar wiring harnesses can be used together.

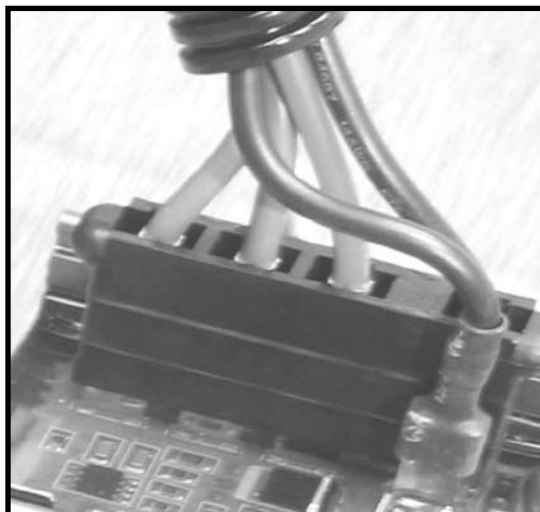
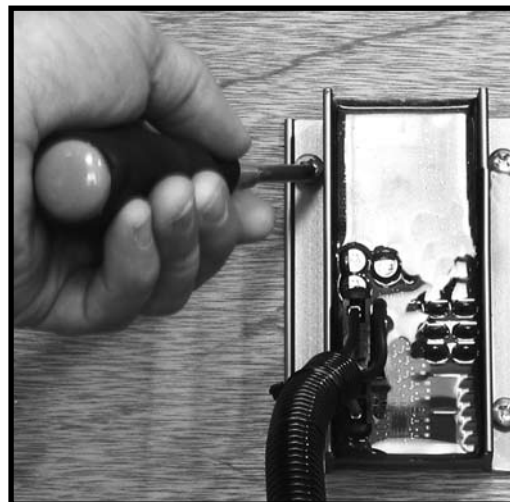

MC-612-DUAL Regulator Terminal Layout

1. **GROUND INPUT (ALTERNATOR #2)** - Connects regulator to system ground via alternator ground terminal. BLACK wire included in Ford style plug.
2. **GROUND INPUT (ALTERNATOR #1)** - Connects regulator to system ground via alternator ground terminal. Loose BLACK wire included in regulator wiring harness or to second wiring harness.
3. **POWER INPUT (ALTERNATOR #2)** - Supplies power to operate the regulator and deliver field current to excite alternator. RED wire included in Ford-style plug.
4. **POWER INPUT (ALTERNATOR #1)** - Supplies power to operate regulator and deliver field current to excite alternator. RED wire in second alternator harness.
5. **IGNITION INPUT (ALTERNATOR #1)** - Connects to a switched source of battery voltage (to ignition switch or oil pressure switch. BROWN wire in regulator wiring harness.
6. **FIELD OUTPUT (ALTERNATOR #2)** - Provides external (P-type) alternator field control for the secondary alternator. BLUE wire in secondary wiring harness.
7. **FIELD OUTPUT (ALTERNATOR #1)** - Provides external (P-type) alternator field control for the primary alternator. BLUE wire in regulator wiring harness.
8. **ALT. TEMP. #1 (-)** - For use with optional Alternator Temperature Sensor (MC-TS-A).
9. **ALT. TEMP. #1 (+)** - For use with optional Alternator Temperature Sensor (MC-TS-A). Sensor lug connects to rear case bolt of alternator, enabling regulator to monitor and react to alternator over-temperature condition. USE CARE TO ENSURE CORRECT PIN POLARITY WHEN CONNECTING SENSOR CABLE TO THE REGULATOR.
10. **BAT. TEMP. #1 (-)** - For use with optional Battery Temperature Sensor (MC-TS-B).
11. **BAT. TEMP. #1 (+)** - For use with optional BATTERY Temperature Sensor (MC-TS-A). Sensor lug connects to negative battery post, enabling regulator to monitor and respond to battery temperature condition. USE CARE TO ENSURE POSITIVE AND NEGATIVE WIRES ARE CONNECTED TO THE APPROPRIATE REGULATOR TERMINAL.
12. **POSITIVE VOLTAGE SENSE** - Connects to battery being charged. Use RED fused pigtail connector (included) at battery end of user-installed wire. The POSITIVE VOLTAGE SENSE wire MUST be connected for the regulator to work.
13. **DATA RX (Factory use only).**
14. **DATA TX (Factory use only).**
15. **STATOR IN** - Connect to WHITE wire included in regulator wiring harness.
16. **TACHOMETER OUT** - Connect to tachometer sender wire when using stator output to provide a signal for an electric tachometer. NOT REQUIRED when a mechanical tachometer is used.
17. **ALT. #2 / BAT. #2 TEMP. (-)** - For use with optional Alternator Temperature Sensor (MC-TS-A) or Battery Temperature Sensor (MC-TS-B).
18. **ALT. #2 / BAT. #2 TEMP. (+)** - User selectable circuit can be used to temperature sense at a second alternator or a second battery bank. Requires either optional MC-TS-A or MC-TS-B sensor cable. USE CARE TO ENSURE POSITIVE AND NEGATIVE WIRES ARE CONNECTED TO THE APPROPRIATE REGULATOR TERMINAL.
19. **AUX. #1 LAMP** - provides a source of ground under the following conditions: Full Field (the alternator is working at full power), Small Engine Mode (the regulator is being controlled at 50% field output), or Equalization Mode. Connect to negative terminal of audible alarm or lamp. 500 mA maximum.
20. **DASH LAMP** - provides a source of ground under the following conditions: Low charging voltage (<12.5V), high charging voltage (>15.5V), high alternator temperature (>105°C), or high battery temperature (>52°C). 500 mA maximum.

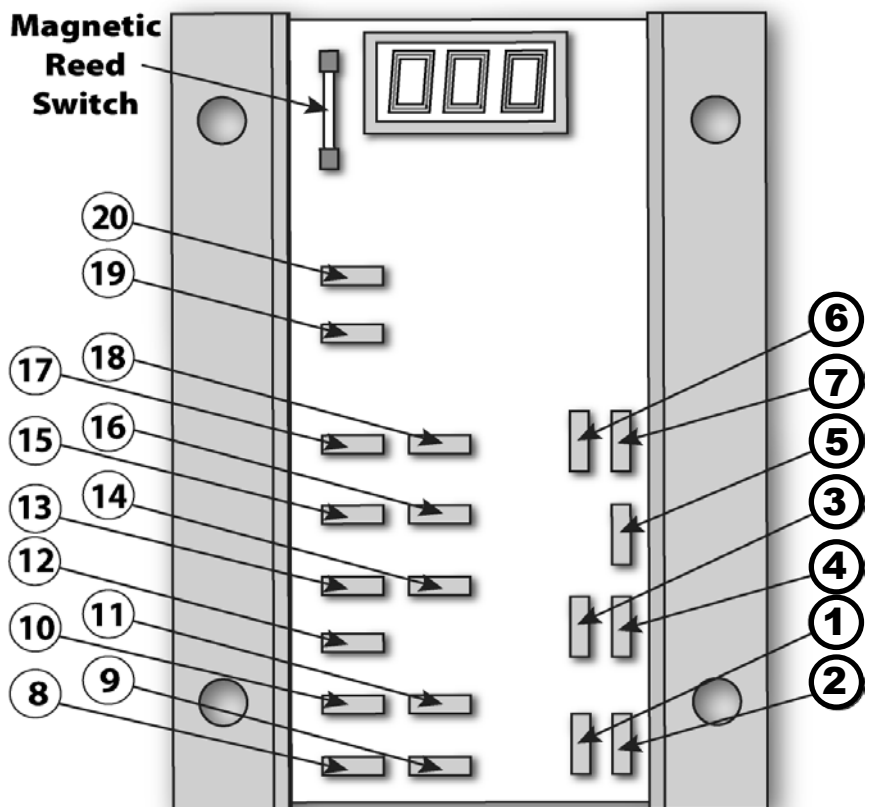

Installation By Wire

Install BLACK Ground Wire(s)

The BLACK Ground Wires (#1 and #2 in diagram at right) are included in the four-wire Ford-style plugs on the PRIMARY and SECONDARY wiring harnesses and are factory installed on regulator packages designated with "H" at the end of the model number. The other end of the Ground Wire is fitted with a ring terminal connector. In most applications, this wire can be connected directly to the alternator's ground terminal post. Both alternators and regulators must be connected to system ground. Check continuity between primary and secondary alternator ground terminals to ensure minimal resistance.

Install RED Power Wire(s)

The RED Power Wires (#3 and #4 in diagram at right) are included in the four-wire Ford-style plugs on the PRIMARY and SECONDARY wiring harnesses and are factory installed on regulator packages designated with "H" at the end of the model number. The other end of the Power Wire is fitted with a ring terminal connector. In most applications, this wire can be connected directly to the alternator's positive output post. When a diode-type battery isolator is used, the primary and secondary power wires must be connected to the battery side of the battery isolator. Power Wires are equipped with 15-amp ATC type fusing. PRIMARY and SECONDARY wires must be fused.

Install BROWN Ignition Wire

The BROWN Ignition Wire (#5 in diagram at right) provides the ON/OFF voltage for the regulator. This wire is included in the Ford-style plug at the regulator end of the PRIMARY wiring harness. The other end of the wire is fitted with a butt connector. Typically, the ignition wire is connected to the ON side of the ignition switch. This may be at the actual switch, or to the wire in the existing engine wiring loom that delivers switched voltage from the ignition switch. In some cases, an oil pressure switch may be used to activate the regulator. In either case, the regulator's ignition wire must see zero volts when the engine ignition is switched off. **Only one ignition wire is required to activate the regulator.**

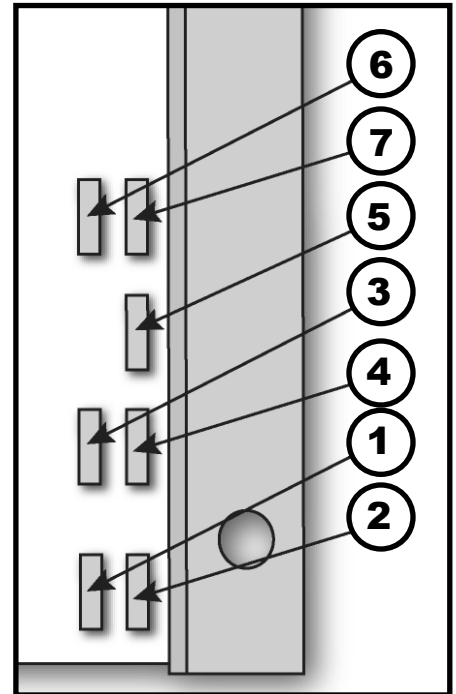

Install BLUE Field Wire(s)

The BLUE Field Wires (#6 and #7 in diagram at right) provide regulated voltage to the alternators to excite the rotors and stators and control alternator output. The wire is included in the wiring harness Ford-style plug and is pre-connected at the regulator. At the other end of the wire, you'll find either a plug or a ring terminal, depending on the alternator's field terminal connection. Attach the field wire to the alternator's field terminal. Field wires should be equal in length. See your alternator manual for any specific requirements your alternator may have.

Install Alternator #1 Temperature Sensor

The optional Alternator Temperature Sensor (MC-TS-A) allows your Max Charge voltage regulator to monitor your alternator for temperatures in excess of safe operating levels. The MC-TS-A sensor assembly includes a 54" cable, a sensing attachment lug and positive and negative regulator plug-in connectors. To install the MC-TS-A:

1. Connect the sensor lug to one of the four bolts that hold the alternator's front and rear cases together. Extend sensor cable to the regulator. The cable can be included within the regulator's wiring harness, or can be run alongside the harness and attached with cable ties.
2. Connect the positive and negative female connectors to the Alternator Temp. Sense terminals on the regulator (#8 is NEGATIVE. #9 is POSITIVE). It is essential that the terminals match the polarity of the regulator connection pins (red wire to positive terminal and black wire to negative terminal).

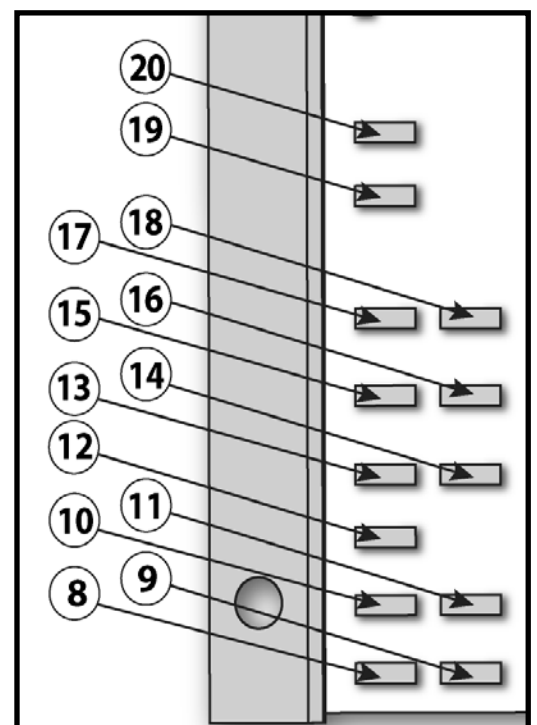

Install Battery #1 Temperature Sensor

The optional Battery Temperature Sensor (MC-TS-B) enables the regulator to monitor for changes in ambient battery temperature, and adjust charging voltages to suit. The MC-TS-B sensor assembly includes a 20-foot cable, a sensing attachment lug and positive and negative regulator plug-in connectors. To install the MC-TS-B:

1. Connect the sensor lug to the battery negative post closest to the center of the battery bank. Extend sensor cable to the regulator
2. Connect the positive and negative female connectors to the Battery temperature sensors on the regulator (#10 is NEGATIVE. #11 is POSITIVE). NOTE: Wire terminals must match the polarity of the regulator connection pins (red wire to positive terminal and black wire to negative terminal).

Install Positive Battery Sense Wire

Included with the MC-612's wiring harness kit is a fused wiring pigtail which features a ring terminal at one end and a butt connector at the other. In the center is a 1-Amp ATC-type fuse and fuse holder. This wire must be connected at the #12 Positive Battery Sense terminal. A female quick connect plug has been pre-attached on the terminal #12 pin. To complete installation of the sense circuit:

1. Identify the favored location for battery sensing. In most instances, the positive output of the alternator, the common side of a battery switch, or the positive post of the battery being charged will work best. If the batteries are connected to a battery isolator, the positive sense wire must be connected to the battery side of the isolator, preferably at the larger of the battery banks.
2. Attach the included wiring pigtail with 1-amp fuse to a length of wire of sufficient to reach from the regulator to the desired sensing location. If the length of the wire run between the regulator and the sensing location is 8' or less, a 16-gauge wire is satisfactory. If the wire run exceeds 8', increase the wire size to 14 gauge.
3. Remove the female 1/4" spade terminal from the terminal #12 pin. Crimp the spade terminal to the sense wire and reconnect the spade to the #12 terminal pin.

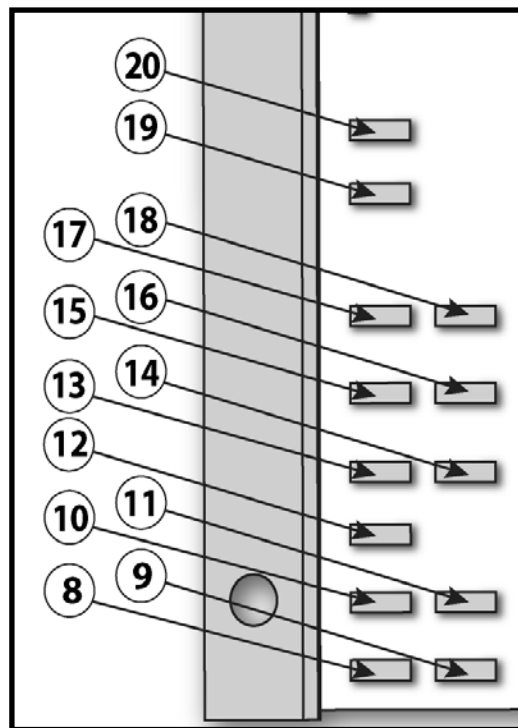

Data TX and RX Terminals (#13 and #14)

Are currently for factory use only, and do not require connection at the regulator.

Install WHITE Stator-In And Tach-Out Wires

The alternator's stator output provides the electrical pulse needed to drive the tachometer. The MC-612-DUAL provides regulated tach output when the WHITE stator wire is connected to the regulator's Stator In (#15 in diagram) terminal and the outfeed wire to the electric tachometer is connected to the Tach Out terminal (#16 in diagram).

Most Balmar alternators feature 12-pole rotors and stators, though, in some cases, the pole count may be 14. See alternator manual for specifics. See your tachometer manual for adjustment instructions.

Install Battery #2 / Alternator #2 Temperature Sensor

Your Max Charge MC-612-DUAL voltage regulator can accommodate either alternator or battery temperature sensing on terminals #17 and #18, depending on your preference. When controlling two alternators with the MC-612-DUAL, the use of a secondary alternator temperature sensor enables the regulator to respond to over-temperature conditions at the second alternator. Used in conjunction with an optional MC-TS-B battery temperature sensor, the regulator can monitor temperature at a secondary battery bank, and respond to a battery over-temperature condition by discontinuing charging.

To install a secondary temperature sensor:

1. Select the optional sensor that best fits your application.
2. Connect the temperature sensor to the secondary alternator or battery bank following the directions provided for the primary alternator or battery temperature sensor.
3. Plug the sensor cable BLACK (negative) wire to #17 and RED (positive) wire to #18. Select the program setting in the voltage regulator's basic program mode that corresponds to your sensing selection.

CAUTION: Reversing the polarity of the terminal connections on any of the alternator or battery temperature sensors can result in invalid sensing and potential damage to alternators, regulator and/or batteries.

Install Aux. 1 Lamp

The Max Charge MC-612-Dual regulator's Aux. #1 (#19) terminal provides the ability to use a visual indicator when the regulator is operating under the following conditions: Full field (the alternator is working at 95% or greater output) or Small Engine Mode (the regulator is being controlled at 50% field output). When a described condition is detected, the regulator sends the Aux. #1 terminal from neutral to ground. To utilize the Aux. #1 Lamp function:

1. Connect a small LED or incandescent lamp (maximum current flow is 500 mA) to a positive voltage source.
2. Connect the negative terminal on the lamp to the Aux. #1 terminal on the regulator.

Install Dash Lamp

The Max Charge Dash Lamp (#20) terminal provides the ability to activate a visual or audible indicator when the regulator monitors the following conditions: Low system voltage, high system voltage, high alternator temperature and high battery temperature (temperature conditions are only indicated when appropriate temperature sensors are connected). When a described condition is detected, the regulator sends the Dash Lamp terminal from neutral to ground. To utilize the Dash Lamp function:

1. Connect a small LED or incandescent lamp, or an audible (piezo) alert (maximum current flow is 500 mA) to a positive voltage source.
2. Connect the negative terminal on the lamp or audible alert to the Dash Lamp terminal on the regulator.
3. When connected, the lamp should flash at regulator start-up to indicate active status.

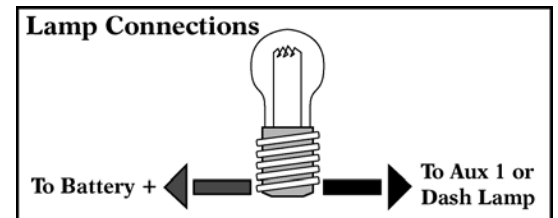
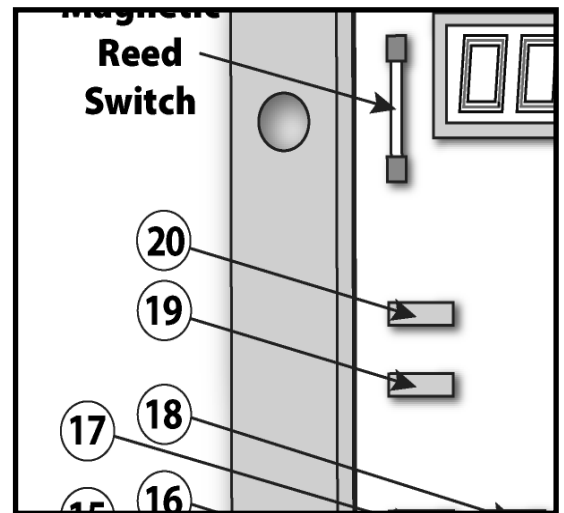

Magnetic Reed Switch

Looking much like a small thermometer atop the regulator's circuit board, the magnetic reed switch provides a durable, sealed interface that enables the user to set basic and advanced regulator programming features. Included with the regulator is a small screwdriver that doubles as the regulator's programming tool. A small magnet embedded in the tip of the screwdriver's handle allows the user to activate the magnetic reed switch. By holding the magnet to the RED dot located at the end of the reed switch, the user allows the user to scroll through the regulator's various program modes and individual program selections.

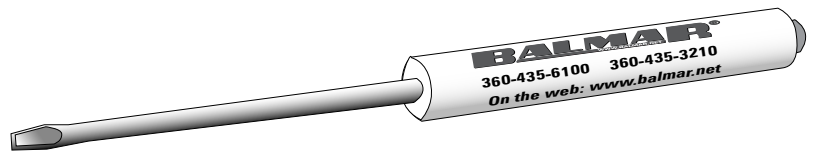

Initial Pre-Flight Test And Start-Up

When the regulator is properly mounted and the regulator wiring is installed, the MC-612-Dual is ready for pre-flight testing. Before turning on the engine, it is advisable to check voltages at the following terminal connections to ensure that the wiring is correct. Test #1 verifies proper voltage values with the regulator turned off. Test #2 verifies the expected voltages with the regulator turned on.

Note: If the regulator's BROWN ignition wire is receiving its switched source of voltage from an oil pressure switch, it may be necessary to start the engine before applying test #2. If the engine must be run to accomplish test #2, be sure that both alternators are properly cabled on both positive and negative sides to the battery being charged. Failure to do so could result in damage to the regulator and alternators.

Using your hand-held multi-meter, test the following wiring terminals for voltage:

TEST #1: Engine/Ignition Off

- Primary RED Power Wire (Terminal #5) >12V
- Secondary RED Power Wire (Terminal #4) >12V
- Positive Voltage Sense Wire (Terminal #12) >12V
- BROWN Ignition Wire (Terminal #3) 0V
- Primary BLUE Field Wire (Terminal #2) 0V
- Secondary BLUE Field Wire (Terminal #1) 0V

TEST #2: Engine/Ignition ON

- Primary RED Power Wire (Terminal #5) >12V
- Secondary RED Power Wire (Terminal #4) >12V
- Positive Voltage Sense Wire (Terminal #12) >12V
- BROWN Ignition Wire (Terminal #3) >12V
- Primary BLUE Field Wire (Terminal #2) 4-12V
- Secondary BLUE Field Wire (Terminal #1) 4-12V

Regulator Operation





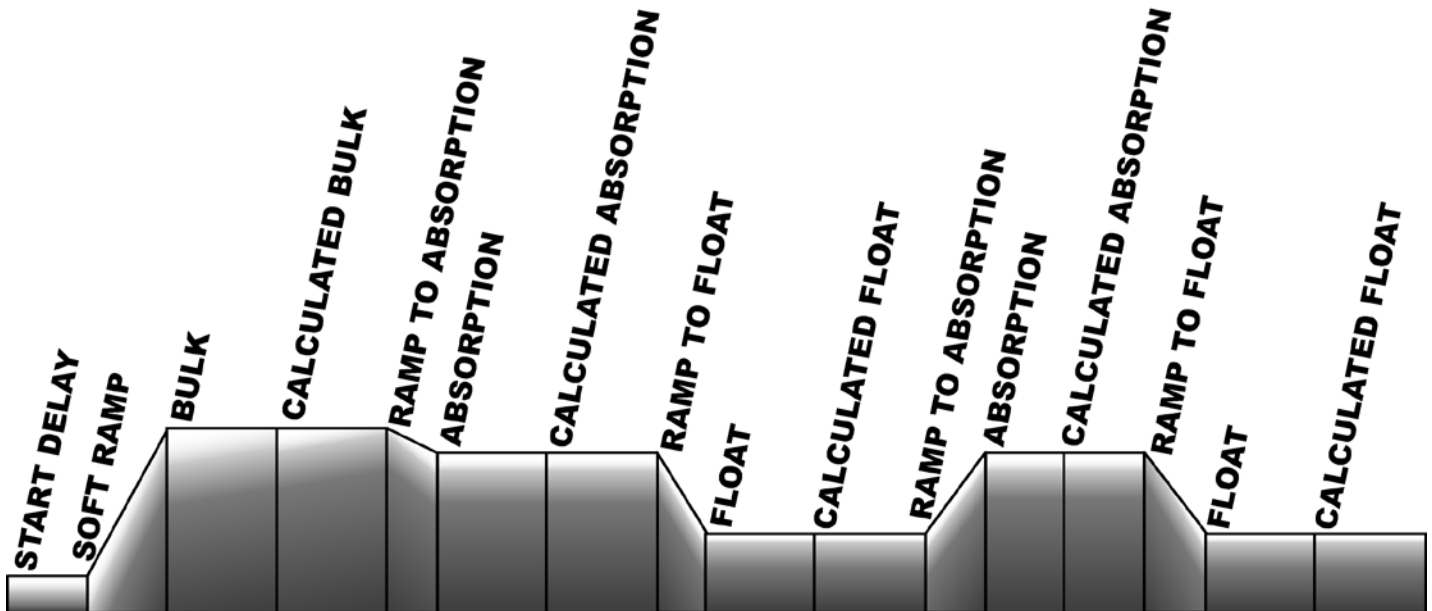





The MC-612-DUAL regulator's microprocessor controlled charging system uses a sophisticated, multi-stage profile to deliver maximum charging output, while protecting the batteries from overcharging damage. When the regulator is first turned on, the processor performs a quick one-second self diagnostic assessment. Following that diagnostic, the MC-612-DUAL initiates a charge program as follows:

1. Start Delay - Factory set at one second. Can be user-adjusted to a maximum of 200 seconds in the regulator's advanced programming mode. See Advanced Programming section for adjustment instructions.
2. Soft Ramp - Gently increases voltage to bulk preset levels based on battery program selected.
3. Bulk Charge - The most aggressive of the charging stages. Voltage is held at a pre-set level, specified by battery program selected, for a set time period. Factory-set bulk time is 30 minutes. Adjustable in 6-minute increments.
4. Calculated Bulk Charge - Holds voltage at bulk level for six minutes, then calculates battery condition by comparing existing voltage, time at voltage, and field percentage to target values. If values are met, the regulator advances to the next stage. If values are not met, the regulator extends the bulk charge time by an additional six minutes and compares real-time to target values. This will re-occur until all values are met.
5. Ramps down to Absorption voltage.
6. Absorption Charge - Regulator continues to control the alternator's output voltage for an additional 30 minutes at approximately 2/10's of a volt below bulk charging voltage. Adjustable in 6-minute increments.
7. Calculated Absorption Charge - Holds voltage at absorption level for six minutes, then calculates battery condition by comparing existing voltage, time at voltage, and field percentage to target values. If values are met, the regulator advances to the next stage. If values are not met, the regulator extends the absorption charge time by an additional six minutes and compares real-time to target values. This will re-occur until all values are met.
8. Ramp down to Float.
9. Float Charge - Regulator continues to control the alternator's output voltage for an additional 30 minutes, typically at a volt less than bulk voltage (based on battery program presets). Regulator will hold voltage to float level for two hours (time duration is user-adjustable). After that initial fixed time period, the regulator can respond to increased charging demand by cycling to absorption voltage. After six hours of continuous operation, the regulator will automatically revert to absorption voltage through calculated absorption and back to float charging stage.











Regulator Display Modes - Basic Display/Long Display

The regulator's three digit alphanumeric LED display provides a scrolling view of charging status. Under normal operation, the display will indicate the following:





















-  Indicates Max Charge MC-612-DUAL.
-  Indicates regulator's default Universal Factory Program. Display will vary based on program selected.
-  Indicates the regulator's Belt Load Manager setting. Ranges from b-0 to b-7.
-  Indicates stage of charge. "b" indicates bulk. "A" indicates absorption. "F" indicates float.
-  Indicates "real time" battery system voltage. Followed by actual voltage reading.
-  Indicates Calculated voltage (target voltage based on preset program levels). Followed by voltage reading.
-  Indicates Battery #1 temperature. Followed by NC (not connected), or temperature in celsius.
-  Indicates Alternator #1 temperature. Followed by NC (not connected), or temperature in celsius.
-  Indicates Battery #2 temperature. Followed by NC (not connected), or temperature in celsius.
-  Indicates Alternator #2 temperature. Followed by NC (not connected), or temperature in celsius.

** Alt. #2 or Bat. #2 Temperature Sensing are user selectable. One or the other will be shown in the regulator display.*

In addition to the information provided in the basic display shown above, the MC-612-DUAL long display provides the following data. The long display is accessed during basic programming, which will be discussed in the next section of the manual.

-  Indicates the percentage of field output to the alternator. The higher the percentage, the greater the output.
-  Indicates regulator's software revision code.
-  Indicates temperature setpoint for ambient alternator and battery temperatures. Followed by degrees celsius.
-  Indicates, in milliamps, the resistance value used to control voltage compensation for battery temperature.
-  Indicates overall regulator hours. Followed by hours (by tenths) and hours in excess of 100.
-  Indicates field threshold from bulk to absorption. Factory set at 67%. Adjust in advanced programming mode.
-  Indicates field threshold from float to absorption. Factory set at 67%. Adjust in advanced programming mode.
-  Indicates system advisory codes. Individually numbered codes are defined below.

The following advisory codes can be used to determine possible system errors or to identify specific operational modes. Note that E codes are cumulative and will be held in memory until cleared. Codes can be by cycling from LD to SD in the basic programming mode, and back to LD after the SD mode has been saved. See basic programming for more info.

- | | | |
|--|--|--|
|  BATTERY #1 TEMP. SENSOR CABLE SHORTED |  ALTERNATOR #2 TEMP. SENSOR CABLE OPEN OR NOT FOUND |  BATTERY #1 TOO HOT. OVER USER ADJUSTED VALUE |
|  BATTERY #1 TEMP. SENSOR CABLE OPEN OR NOT FOUND |  BATTERY #1 TOO HOT. OVER 52°C. FACTORY DEFAULT |  BATTERY #2 TOO HOT. OVER USER ADJUSTED VALUE |
|  BATTERY #2 TEMP. SENSOR CABLE SHORTED |  BATTERY #2 TOO HOT. OVER 52°C. FACTORY DEFAULT |  FIELD VOLTAGE TOO HIGH |
|  BATTERY #2 TEMP. SENSOR CABLE OPEN OR NOT FOUND |  ALTERNATOR #1 TOO HOT. OVER 108°C |  STATOR VOLTAGE TOO HIGH |
|  ALTERNATOR #1 TEMP. SENSOR CABLE SHORTED |  ALTERNATOR #2 TOO HOT. OVER 108°C |  SMALL ENGINE MODE IS IN OPERATION |
|  ALTERNATOR #1 TEMP. SENSOR CABLE OPEN OR NOT FOUND |  VOLTAGE REGULATOR TOO HOT. OVER 90°C |  BATTERY #2 TEMPERATURE SENSE MODE |
|  ALTERNATOR #2 TEMP. SENSOR CABLE SHORTED |  BATTERY SENSE WIRE OPEN OR NOT FOUND |  ALTERNATOR #2 TEMPERATURE SENSE MODE |

Regulator Programming Modes Using The Magnetic Reed Switch

Control of the MC-612-DUAL regulator's basic and advanced programming modes is provided by a magnetic reed switch located in the upper left corner of the regulator's circuit board. The reed switch provides selectable control of the regulator's programming without creating an intrusion point as is common on many other adjustable voltage regulators currently on the market.

A small screwdriver with a magnet embedded in the tip of the handle is included to activate the magnetic reed switch. While any magnetic tipped tool can be used, the Balmar programming screwdriver does an excellent job as an interfacing tool.

Programming is accomplished by contacting and removing the magnet from the RED dot affixed to the regulator's epoxy potting. If the magnet has difficulty activating the reed switch at that position, try moving the up and down along the length of the reed switch until the RED light is illuminated at the top of the LED display, between the second and third display digits. The RED light indicates activation of the the reed switch.

Within the basic and advanced programming instructions, activation of the reed switch will be described by the following actions:

- **TOUCH / RELEASE** - Indicates the action of contacting and immediately removing the magnet from the reed switch
- **TOUCH / HOLD** - Indicates the action of contacting and holding the magnet to the reed switch
- **TOUCH / HOLD / RELEASE** - Indicates the action of contacting and holding the magnet to the reed switch, then releasing the reed switch by removing the magnet from the RED dot on the epoxy potting

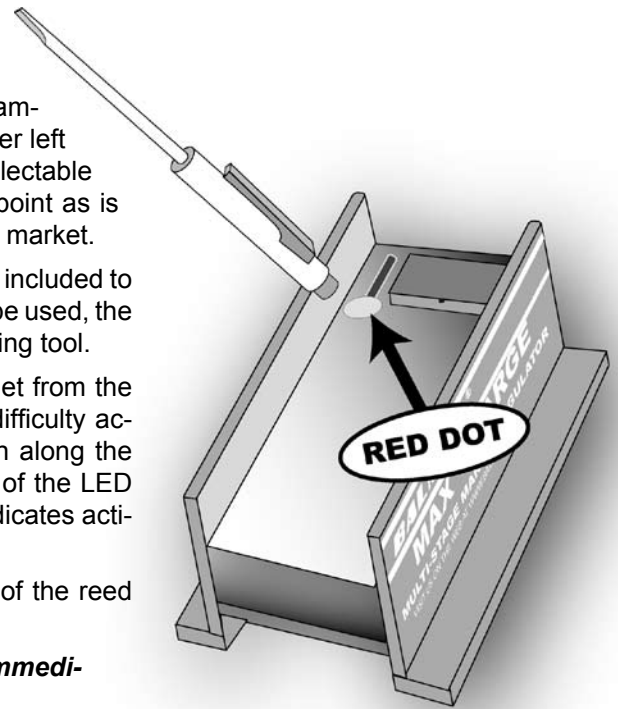

Basic Programming Programming For Battery Type

The MC-612-DUAL features selectable programs for the following battery technologies; Standard Flooded (FSb), Deep Cycle Flooded (FdC), gel (gEL), AGM (AgL), Optima (OPS), as well as a factory default program (UFP) and a program for systems with voltage sensitive halogen equipment (HAL). Programming can be accomplished whenever the regulator is activated. **System voltage must be greater than 12.5V for programming changes to take place.**

When activating the programming mode, keep in mind that the regulator will scroll through the basic programming mode three times before saving and returning to the operational mode. To adjust the regulator for your battery type:

1. Turn on the regulator. This may be accomplished by turning the ignition switch at the panel to the ON position. If the regulator's BROWN ignition wire is connected to an oil pressure switch, it may be necessary to start the engine to activate the regulator.
2. Once the regulator is on and the display is scrolling, TOUCH / HOLD the magnetic end of the programming screwdriver to the RED dot on the regulator as described above.
3. Continue to hold the magnet to the RED dot. The letters PRO will appear on the LED.
4. Continue to hold the magnet to the RED dot. The letters BA will appear on the LED.
5. Continue to hold the magnet to the RED dot. The LED display will begin to scroll through the various battery codes.
6. When the desired battery code is displayed, RELEASE the magnet from the RED dot.
7. The display will indicate BA once again. At this point, you have the option to re-enter the battery type mode by re-applying the magnet to the RED dot. Otherwise, the display will cycle to bEL, indicating entry into the Belt Load Manager mode.



INDICATES ENTRY INTO BASIC PROGRAMMING MODE



INDICATES PROGRAM FOR DEEP CYCLE GEL BATTERIES



INDICATES PROGRAM FOR STD. FLOODED BATTERIES



INDICATES ENTRY INTO BATTERY TYPE PROGRAM MODE



INDICATES PROGRAM FOR ABSORBED GLASS MAT BATTERIES



INDICATES PROGRAM FOR HALOGEN SYSTEMS



INDICATES FACTORY DEFAULT UNIVERSAL FACTORY MODE



INDICATES PROGRAM FOR SPIRAL WOUND (OPTIMA) BATTERIES



INDICATES ENTRY INTO BELT LOAD MANAGER MODE



INDICATES PROGRAM FOR DEEP CYCLE FLOODED BATTERIES











Basic Programming

Programming The Belt Load Manager

The MC-612-DUAL provides the ability to manage regulator field potential, making it possible to govern the horsepower loads placed on the drive belt(s) by the alternator. The Belt Load Manager can also be used to protect the alternator from extraordinary load created by a battery load that's too large for the alternator's capacity. The Belt Load Manager is accessed in the basic programming mode, directly after the battery type programming mode. The Belt Load Manager can be accessed at the same time the battery program is set, or by itself. To program the Belt Load Manager

When activating the programming mode, keep in mind that the regulator will scroll through the basic programming mode three times before saving and returning to the operational mode. To adjust the regulator for your battery type:

1. Turn on the regulator. This may be accomplished by turning the ignition switch at the panel to the ON position. If the regulator's BROWN ignition wire is connected to an oil pressure switch, it may be necessary to start the engine to activate the regulator.
2. If the battery type program has been adjusted, TOUCH / HOLD when entry into the Belt Load Manager is indicated by the bEL display on the regulator's LED.
3. If you don't wish to adjust the battery programming, TOUCH / HOLD the RED dot when the regulator is activated. RELEASE when the Pro display is indicated. The regulator will indicate bA, for battery type, and will cycle to bEL.
4. TOUCH / HOLD. The regulator display will indicate b-0 (indicating that the Belt Load Manager is off). Continue to HOLD. The regulator display continue to scroll through seven settings. Each setting decreases the field potential by approximately seven percent.
5. RELEASE when the display indicates your desired level of field reduction. The display will cycle to bEL. You can re-activate to change your selection, or wait until the regulator cycles to the next programming mode.
6. The display will cycle to Ab2, indicating the selection mode where the user can toggle between a secondary alternator temperature sensor or a secondary battery temperature sensor on terminals #16 and #17.

	INDICATES ENTRY INTO BELT LOAD MANAGER MODE		INDICATES BLM SETTING #3. FIELD REDUCTION APPROX. 21%.		INDICATES BLM SETTING #6. FIELD REDUCTION APPROX. 42%.
	INDICATES BLM SETTING #0. NO FIELD REDUCTION.		INDICATES BLM SETTING #4. FIELD REDUCTION APPROX. 28%.		INDICATES BLM SETTING #7. FIELD REDUCTION APPROX. 49%.
	INDICATES BLM SETTING #1. FIELD REDUCTION APPROX. 7%.		INDICATES BLM SETTING #5. FIELD REDUCTION APPROX. 35%.		INDICATES ENTRY INTO PROGRAM FOR 2ND POSITION TEMP SENSING.
	INDICATES BLM SETTING #2. FIELD REDUCTION APPROX. 14%.				

Programming For Secondary Alternator OR Regulator Temperature Sensor

The regulator allows the user to select between the use or a second battery temperature sensor, or a second alternator temperature sensor, depending on the application and preference. To adjust the regulator for secondary sensor type:

1. TOUCH / HOLD when entry into the temperature sensor selector is indicated by the Ab2 display on the LED.
2. The regulator display will indicate codes AL2 (for alt. temp. sensor #2) or b2 (for bat. temp. sensor #2).
3. RELEASE when the display indicates your desired temperature sensor type. The display will cycle to Ab2. You can re-activate to change your selection, or wait until the regulator cycles to the next programming mode.
4. The display will cycle to dSP, indicating the selection mode for short (Sd) or long (Ld) regulator displays.

	INDICATES ENTRY INTO ALT/BAT #2 SELECTOR MODE		INDICATES SELECTION MODE FOR 2ND BATTERY SENSE MODE
	INDICATES SELECTION MODE FOR 2ND ALTERNATOR SENSE		INDICATES ENTRY INTO SHORT OR LONG DISPLAY MODE

Programming For Short Or Long Display Mode

You can choose the amount of information displayed on the regulator. The information displayed on the short or long display is detailed on Page 8 of the manual. To adjust the regulator for short or long display:

1. TOUCH / HOLD when entry into the short/long display selector is indicated by dSP on the regulator's LED.
2. The regulator display will indicate codes Sd (for short display) or Ld (for long display).
3. RELEASE when the display indicates your desired display mode. The display will cycle to dSP. You can re-activate to change your selection, or wait until the regulator cycles to the next programming mode.

	INDICATES ENTRY INTO SHORT OR LONG DISPLAY MODE		INDICATES SELECTION MODE FOR SHORT DISPLAY
	INDICATES SELECTION MODE FOR LONG DISPLAY		INDICATES END OF BASIC DISPLAY MODE

Advanced Programming

Accessing The Advanced Programming Mode

The MC-612-DUAL provides a broad range of advanced user adjustments in its password-protected Advanced Program mode. The Advanced Program mode is accessed via the Basic Program mode. To access the Advanced Program mode:

1. With the regulator activated, TOUCH / HOLD the magnet to the RED dot on the regulator's epoxy potting.
2. The regulator will cycle to PRO. RELEASE the magnet from the switch.
3. The regulator will cycle through all of the Basic Program modes; bA, bEL, Ab2, and dSP -- followed by three dashes.
4. TOUCH / HOLD when the three dashes are displayed. The dashes will be replaced by AP0 followed by AP1, and so on.
5. When the display indicates AP5, RELEASE.
6. The display will cycle to PrA, indicating entry into the Advanced Programming mode.



INDICATES ENTRY INTO PROGRAM MODE



INDICATES SELECTION MODE FOR BAT / ALT #2 TEMP SENSE



INDICATES ENTRY INTO PASSWORD MODE FOR AP MODE



INDICATES SELECTION MODE FOR BATTERY TYPE



INDICATES SELECTION MODE FOR SHORT/ LONG DISPLAY



INDICATES PASSWORD FOR ADVANCED PROGRAM MODE



INDICATES SELECTION MODE FOR BELT LOAD MANAGER



INDICATES END OF BASIC PROGRAM MODE



INDICATES ENTRY INTO THE ADVANCED PROGRAM MODE

Advanced Programming Modes

Making Advanced Programming Adjustments

Once accessed, the Advanced Program mode allows the user to adjust time, voltage and temperature settings for most operational modes. When the desired mode is indicated, TOUCH / HOLD the magnet to the RED dot on the epoxy potting. When the reed switch is engaged, the values for the various modes will scroll upward or downward. To reverse the direction of scroll:

1. REMOVE the magnet from the reed switch.
2. Wait for the mode indicator to be displayed.
3. TOUCH / HOLD when the mode indicator is displayed. The values for that mode will begin to scroll in the opposite direction. Continue to HOLD until the desired value is displayed.
4. REMOVE the magnet from the RED dot. The mode indicator will be displayed again, followed by the indicator for the next Advanced Programming mode.

The Advanced Programming Modes are as follows:



Advanced Program Mode. Once the correct password has been provided to unlock the Advanced Program mode, the PrA display will be immediately followed by thirteen advanced control modes, including; start delay, compensation limit, bulk voltage and time, absorption voltage and time, float voltage and time, field thresholds, temperature limits and slope.



Start Delay. Controls the amount of time from regulator activation to start of charging. Factory preset at onesecond. Can be adjusted to a maximum of 200 seconds. To reverse direction of scroll, release magnet and wait for LED to display dlc code. Re-activate switch with magnet and release when desired value is indicated.

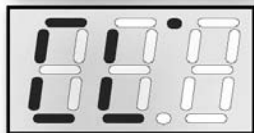

Compensation Limit. Controls the maximum limit of allowable system voltage. Starts at value set by battery program currently in use. Adjustment spans from 14.1 to 15.9 volts. To reverse direction of scroll, release magnet and wait for LED to display Cl code. Re-activate switch with magnet and release when desired value is indicated.

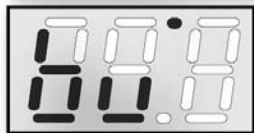

Bulk Voltage. Controls the maximum limit of allowable bulk voltage. Starts at value set by battery program currently in use. Adjustment spans from 14.1 to 14.8 volts. To reverse direction of scroll, release magnet and wait for LED to display bv code. Re-activate switch with magnet and release when desired value is indicated.



Bulk Time. Controls the minimum time period for non-calculated bulk charging. Standard value set by battery program selected. Adjustment spans in tenths of hours from 12 minutes to six hours. To reverse direction of scroll, release magnet and wait for LED to display b1c code. Re-activate switch with magnet and release when desired value is indicated.

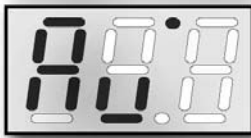

Absorption Voltage. Controls the maximum limit of allowable bulk voltage. Starts at value set by battery program currently in use. Adjustment spans from 13.5 to 14.8 volts. To reverse direction of scroll, release magnet and wait for LED to display Av code. Re-activate switch with magnet and release when desired value is indicated.

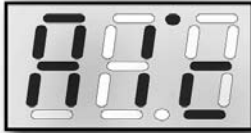

Absorption Time. Controls the minimum time period for non-calculated absorption charging. Standard value set by battery program selected. Adjustment spans in tenths of hours from 12 minutes to six hours. To reverse direction of scroll, release magnet and wait for LED to display a1c code. Re-activate switch with magnet and release when desired value is indicated.



Float Voltage. Controls the maximum limit of allowable float voltage. Starts at value set by battery program currently in use. Adjustment spans from 13.0 to 13.8 volts. To reverse direction of scroll, release magnet and wait for LED to display Fv code. Re-activate switch with magnet and release when desired value is indicated.

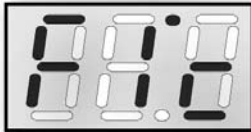

Float Time. Controls the minimum time period for non-calculated float charging. Standard value set by battery program selected. Adjustment spans in tenths of hours from 12 minutes to six hours. To reverse direction of scroll, release magnet and wait for LED to display F1c code. Re-activate switch with magnet and release when desired value is indicated.



Field Threshold - Bulk To Absorption . Controls the criteria the regulator uses to determine how hard the alternator has to be working to stay in calculated bulk charging mode. Factory set at 67% field output. Raising “fba” shortens calculated bulk charge time. Lower ing “fba” increases calculated bulk charge time. Adjusted in 1% increments. Span of adjustment is 16% to 96%. To reverse direction of scroll, release magnet and wait for LED to display “fba” code. Re-activate switch with magnet and release when desired value is indicated.



Field Threshold - Float To Absorption . Controls the criteria the regulator uses to determine how hard the alternator has to be working to stay in calculated absorption charging mode. Factory set at 67% field output. Raising “ffi” shortens “ffi” increases calculated absorption charge time. Adjusted in 1% increments. Span of adjustment is 16% to 96%. To reverse direction of scroll, release “ffi” code. Reactivate switch with magnet and release when desired value is indicated.



Alternator #1 Temperature Threshold. Controls the setpoint at which point field current is reduced when the the alternator temperature sensor indicates an over-temp condition at the alternator. Requires temperature sensor installation. Preset at 108°.



Battery #1 Temperature Threshold. Controls the setpoint at which point field current is discontinued when the the battery temperature sensor indicates an over-temp condition at battery #1. Requires temperature sensor installation. Preset at 52°C.



Slope Voltage Correction. Adjusts the voltage (in millivolts) the regulator uses when monitoring battery temperature sensing. Can be custom adjusted to meet the needs of unique battery technologies. Consult with battery manufacturer for specific slope voltage recommendations.

Default Program Settings By Battery Type

	UFP	FDC	GEL	AGM	OPS	FSB	HAL
START DELAY (SECS.)	1	1	1	1	1	1	1
SOFT RAMP (SECS.)	60	60	60	60	60	60	60
BULK VOLTAGE	14.1	14.6	14.1	14.38	14.6	14.4	14.0
BULK TIME (MINIMUM)	30 MIN	30 MIN	30 MIN	30 MIN	30 MIN	30 MIN	30 MIN
ABSORPTION VOLTS	13.9	14.4	13.9	14.18	14.4	14.2	13.8
ABSORPTION TIME (MINIMUM)	30 MIN	30 MIN	30 MIN	30 MIN	30 MIN	30 MIN	30 MIN
FLOAT VOLTS	13.4	13.4	13.7	13.4	13.4	13.4	13.5
FLOAT TIME (MINIMUM)	30 MIN	30 MIN	30 MIN	30 MIN	30 MIN	30 MIN	30 MIN
FLOAT TIME (MAXIMUM)	6 HRS.	6 HRS.	6 HRS.	6 HRS.	6 HRS.	6 HRS.	6 HRS.
HIGH VOLTAGE ALARM (VOLTS)	15.2	15.6	15.1	15.38	15.6	15.4	15.0
LOW VOLTAGE ALARM (VOLTS)	12.5	12.5	12.5	12.5	12.5	12.5	12.5
MAX BAT. TEMP.	125 F/52 C	125 F/52 C	125 F/52 C	125 F/52 C	125 F/52 C	125 F/52 C	125 F/52 C
MAX ALT. TEMP.	225 F/107 C	225 F/107 C	225 F/107 C	225 F/107 C	225 F/107 C	225 F/107 C	225 F/107 C

Additional Regulator Features

Small Engine Mode

In situations where additional power is needed for propulsion, the MC-612-DUAL provides the option to manually reduce regulator field output by approximately one half. This option, called Small Engine Mode, can be accessed by creating a direct pathway between the positive and negative Alternator #1 Temperature Sensor terminals. This can be done by splicing into the positive and negative wires of the Alternator Temperature Sensor cable (MC-TS-A) with a switched wire. With the switch in the OFF position, the Alternator #1 Temperature Sensor will work normally. With the switch in the ON position, the regulator will reduce field output by approximately 50%.

To enable the Small Engine Mode:

1. If the Alternator Temperature Sensor cable is being used, replace the female terminal connectors on the cable with Multi-Stack Connectors (Ancor Part # 230612).
2. Install a standard ON/OFF switch in a location that's easily reached from the helm.
3. Run wires from the switch back to the positive and negative terminals of the Alternator #1 Temperature Sensor terminals.
4. Add appropriate connectors to the switched wires and connect to the positive and negative terminal connections.

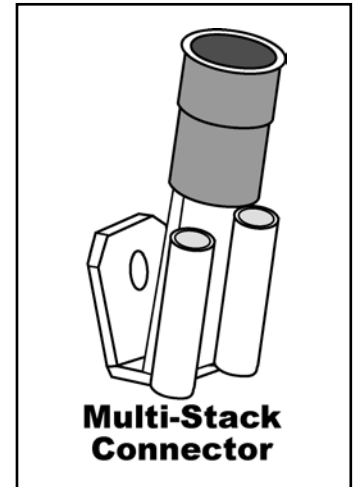

Dash Lamp

The MC-612-DUAL provides a Dash Lamp circuit that's capable of providing a signal to a user supplied and installed audible or visual alert if the following issues were to occur while the regulator is in operation;

- Low Battery Voltage <12.5V
- High Battery Voltage >15.9V
- High Alternator Temp. >225°F/107°C (Requires installation of MC-TS-A sensor cable.) Temperature adjustable.
- High Battery Temp. >125°F/52°C (Requires installation of MC-TS-B sensor cable.)

Follow the instructions provided on Page 6 of this manual when installing.

Aux #1 Lamp

The MC-612-DUAL provides an Auxiliary Lamp circuit that's capable of providing a signal to a user supplied and installed audible or visual alert to indicate the following while the regulator is in operation:

- Small Engine Mode is activated,
- Regulator is at full field.

Follow the instructions provided on Page 6 of this manual when installing.

System Troubleshooting

Regulator Troubleshooting

The majority of charging difficulties can be attributed to damage, corrosion or wear at wiring, fusing or wiring connections. Before attempting to troubleshoot alternator or regulator issues, be sure to address the following:

1. Remove and clean all charging system electrical connections (positive and negative). Check the voltage regulator's harness for resistance. Wires and terminals can and will become corroded, and need to be cleaned or replaced. Ensure that the regulator's ground wires are provided with a clean connection to system ground.
2. Inspect and replace 10A and 1A ATC type fuses in the regulator wiring harness if fuses appear to be damaged or corroded. Ensure that the fuse holder is also free of corrosion.
3. Charge all batteries to their proper fully charged state, and determine if they are serviceable. If your batteries are flooded-type, use your hydrometer to determine their condition.
4. Check and tighten alternator belt. If the belt show signs of wear or damage, replace it. Always replace existing belts with the finest quality replacements available.

If batteries and wiring are in suitable condition, use the tests on the following page to determine if charging problems are a result of a faulty alternator or regulator. These tests provide an opportunity to isolate the alternator, regulator and wiring harness in order to determine the problem source. In order to perform these tests, you will need an independent DC meter (preferably a digital type). In an emergency, a 12V light bulb or test light can be used to help determine if power or working grounds exist. An amp meter and a battery hydrometer with a thermometer are also helpful diagnostic tools.

Voltage Regulator Testing

Set your voltmeter to 12VDC and connect the negative lead to the BLACK ground wire at the regulator as shown at in the diagram at right.

1. With the ignition turned OFF, check voltage on the RED (power), Secondary RED on Terminal #12 (voltage sense) BLUE (field) and BROWN (ignition) wires in the regulator plug.

Voltages should be as follow:

- RED wire equal to battery voltage
- Terminal #12 RED wire equal to battery voltage
- BLUE wire zero volts
- BROWN wire zero volts

With the ignition in the ON position (engine not running), check voltage on the RED (power), Secondary RED on Terminal #12 (voltage sense) BLUE (field) and BROWN (ignition) wires in the regulator plug:

2.
 - RED wire equal to battery voltage
 - Terminal #12 RED wire equal to battery voltage
 - BLUE wire between 4V and 11V
 - BROWN wire equal to battery voltage

PLEASE NOTE: In systems where the ignition (BROWN) wire is supplied power via an oil pressure switch, jump directly from test #1 to test #3.

3. With the ignition in the ON position (with engine running at 1,400 rpm fastidle), check voltage on the RED (power), Secondary RED on Terminal #13 (voltage sense) BLUE (field) and BROWN (ignition) wires in the regulator plug. Voltages should be as follow:

- RED wire equal to battery voltage
- Terminal #12 RED wire equal to battery voltage
- BLUE wire between 4V and 11V
- BROWN wire equal to battery voltage

If voltage is not present on the RED, the BROWN and the Positive Battery Sense Wire, the regulator will not work. If voltage is as expected at the RED the BROWN and Positive Battery Sense wire, and there is zero, or an unexpected voltage reading at the BLUE wire, contact our technical support staff at (360) 435-6100, or e-mail us at balmar@balmar.net.

If all voltages at the regulator meet expectations, yet the alternator is not producing charging current, test the alternator. The following tests are recommended for determining alternator functionality.

Alternator Testing

TEST #1 The following test is used to isolate the alternator and determine if the failure is a result of the alternator. Once again, testing at either the alternator or regulator is only effective if the wiring, fusing and batteries have been determined to be in correct working order. The alternator and regulator can be tested for function by determining if a magnetic field exists at the alternator's pulley shaft or rear bearing. To test:

1. With the ignition in the OFF position, place the tip of a steel screwdriver near the nut on the pulley shaft or near the rear bearing of the alternator. There should be no evidence of a magnetic field pulling the screwdriver toward the alternator. (A slight amount of magnetism may be present, due to residual voltage in the alternator.)
2. Engage the ignition, without starting the engine, to activate the voltage regulator. If an oil pressure switch is used, a jumper between the RED and BROWN wires in the Ford-style plug will activate the regulator.
3. After allowing time for the regulator's start-up delay, place the head of a steel screwdriver near the nut on the pulley shaft or near the rear bearing of the alternator. There should be substantial magnetic pull. If a magnetic field is present, the voltage regulator, alternator brushes and rotor are likely to be working properly.

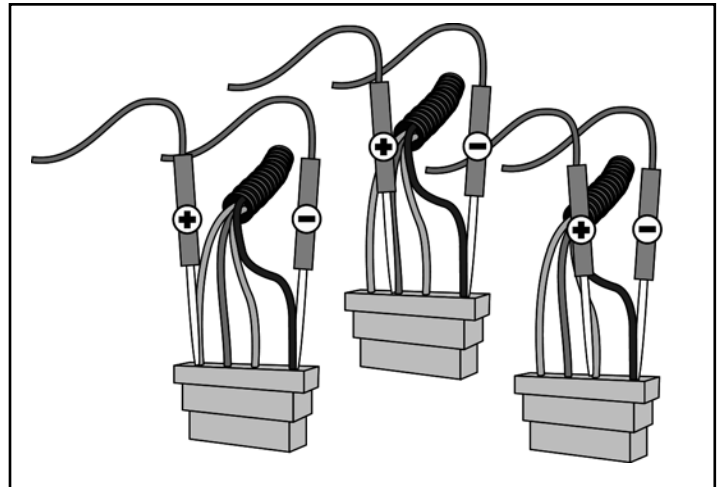

If there is little or no magnetic pull at the pulley shaft or at the rear bearing, initiate the following test:

With the key off and the engine off, remove the large harness plug from the regulator.

1. Insert the end of a short length of electrical wire to the RED connector slot of the regulator harness and the other end of the wire to the BLUE connector slot. This bypasses the regulator and tests the alternator and the harness.
2. Using your steel screwdriver, inspect for a magnetic field as described above.
3. With your voltmeter, check for voltage on the blue wire at the alternator. If voltage does not exist, the harness may be at fault. If voltage does exist at the harness, but no magnetism is present, the alternator is likely to be malfunctioning.
4. If a magnetic field is present. Both harness and alternator brushes and rotor appear to be working properly. If no magnetic field is present, proceed with the next test.

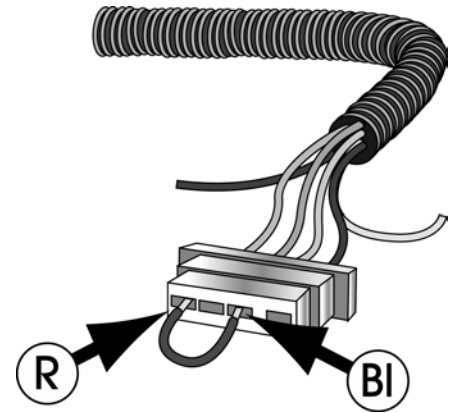

Testing the actual output of the alternator is known as “Full Field Testing”. This can be accomplished by jumping a positive 12VDC current to the field terminal at the rear of the alternator. This test eliminates both the regulator and the harness, making it easier to isolate your investigation to the alternator.

CAUTION: Ensure that all voltage sensitive equipment is turned off prior to starting the engine. Voltage is unregulated during this test and could damage sensitive electronics. **DO NOT** let the engine run any longer than necessary to detect charging. If the system is not charging, remove the alternator and have it inspected by a qualified alternator shop, or call Balmar for warranty evaluation.

To test the alternator:

1. Clip a jumper wire to the positive post of the alternator, or on the battery side of the isolator (if an isolator is in use). Use a SHIELDED alligator clip for post attachment. Unintentional contact between the alligator clip and the alternator case could result in damage to your electrical system.
2. Disconnect the field/stator plug from the rear of the alternator and attach the other end of the jumper wire to the alternator’s Field terminal (F). Attach a female spade connector to the field end of the wire for a solid connection. **CAUTION:** Do not allow the wire to contact the case while it is attached to the positive post. The case is grounded and severe damage could occur.
3. The regulator is now bypassed. When the ignition is engaged and the motor is started, the voltage should rise and charging current should be present.
4. The motor should be run long enough to determine that charging voltage is present. Unregulated voltage can rise quickly. Do not allow extended unregulated charging to occur without carefully monitoring voltage levels. If the alternator fails to generate voltage during field testing, a malfunction of the alternator is likely. Contact your local alternator repair shop or Balmar’s technical service staff for recommendations.

Conclusion

If your readings differ substantially from the “Expected Readings” listed in the troubleshooting charts, the regulator may be malfunctioning, or there may be a continuity problem. Contact our technical support staff at (360) 435-6100. If you determine that repair service is necessary for either your alternator or regulator, please gather the following information before contacting our service technicians: Make and model of alternator. Model of voltage regulator and date of mfg. (date punched on rear side label of regulator). Voltage readings on red, brown and blue wire at regulator with engine off, key on. Voltage readings on red, brown and blue wire at regulator with engine running at a fast ideal 1400 rpm.

NOTES:

Typical MC-612-DUAL System Installation

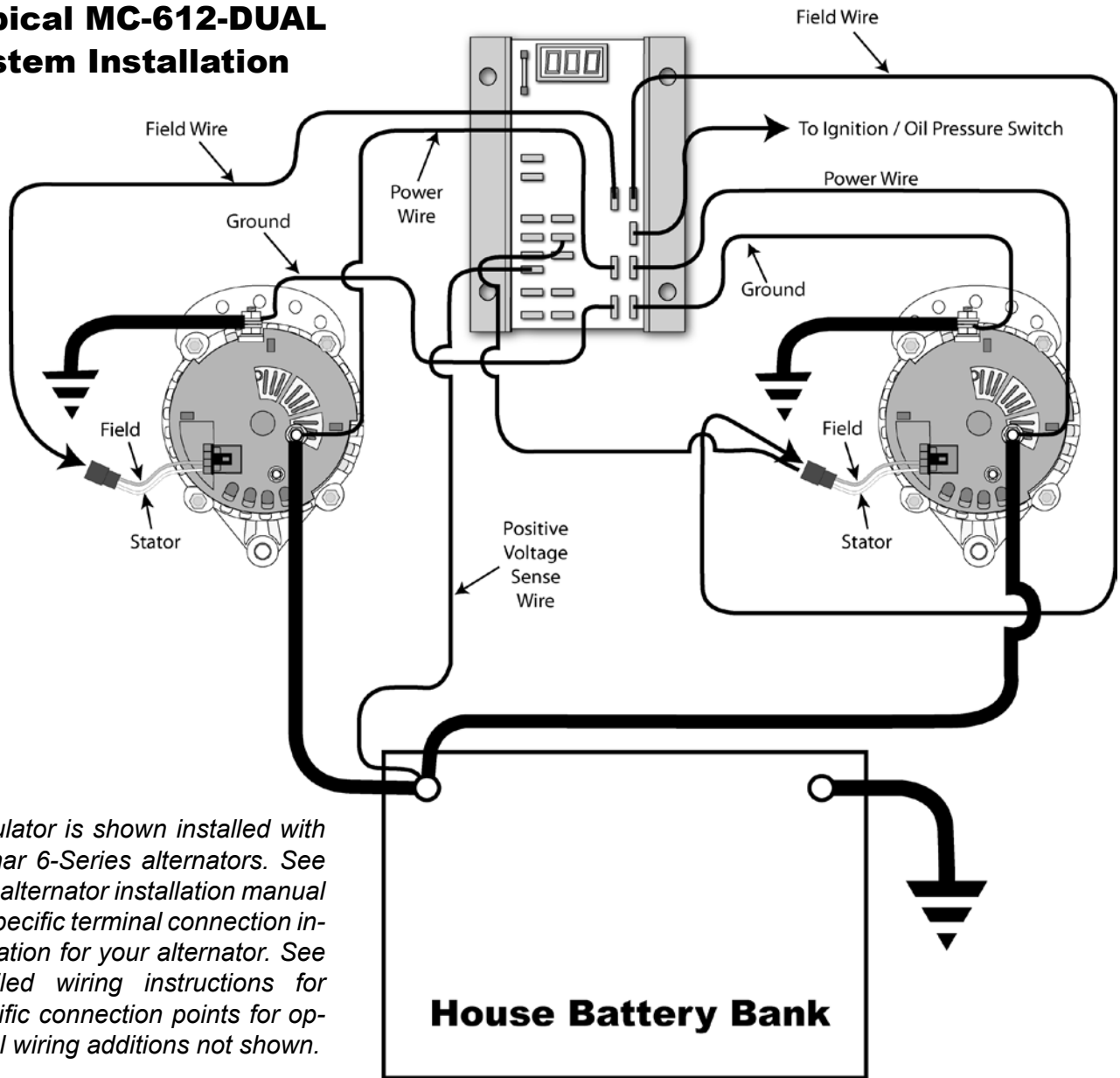

Regulator is shown installed with Balmar 6-Series alternators. See your alternator installation manual for specific terminal connection information for your alternator. See detailed wiring instructions for specific connection points for optional wiring additions not shown.

LIMITED PRODUCT WARRANTY

BALMAR warrants to the original consumer/purchaser the product is free from any defects in material or workmanship for a period of one year from the date of purchase. If any such defect is discovered within the warranty period, BALMAR will replace the regulator free of charge, subject to verification of the defect or malfunction upon delivery or shipping prepaid to BALMAR.

This warranty DOES NOT apply to defects or physical damage resulting from abuse, neglect, accident, improper repair, alteration, modification, or unreasonable use of the products resulting in breakdown, cracked or broken cases nor are parts damaged by fire, water, freezing, collision, theft, explosion, rust, corrosion or items damaged in shipment in route to BALMAR for repair. BALMAR assumes no responsibility for consequential damage or loss or expense arising from these products or any labor required for service or repair.

BALMAR WILL NOT repair or be held responsible for any product sent without proper identification and return address or RA number clearly marked on the package. You must include proof of date and place of purchase (photocopy of purchase invoice) or we cannot be responsible for repairs or replacement. In order to expedite warranty claims more efficiently, BALMAR asks that prior to returning a defective product for repair, you call their customer service department for a warranty return authorization number. If factory service is required, you can contact our BALMAR Customer Service Department Monday through Thursday, 7:30 AM to 5:30 PM, (PST)1-360 435-6100 ext "3". Material required for the repair or replacement for the defective part or product is to be supplied free of charge upon delivery of the defective regulator to BALMAR, 18930 59 Ave. NE, Arlington, WA 98223. Customer is responsible for all return transportation charges and any air or rush delivery expense. BALMAR reserves the right to determine whether to repair or replace defective components.

THE ABOVE LIMITATIONS MAY NOT APPLY TO YOU. SOME STATES DO NOT ALLOW LIMITATIONS ON HOW LONG AN IMPLIED WARRANTY LASTS. NO PERSON, AGENT, DEALER IS AUTHORIZED TO GIVE ANY WARRANTY.

BALMAR 19009 61st Ave. NE, Arlington, WA 98223 Phone: (360) 435-6100, Fax: (360) 435-3210 E-mail: balmar@balmar.net, Web: www.balmar.net