

ARS-4 Installation and Operator's Manual

BALMAR®

I. INTRODUCTION

Thank you for choosing your Model ARS-4 multi-stage regulator. This regulator has been designed to maximize the charging efficiency of your Balmar high-output alternator, and can also be used with many other P-type, externally regulated alternators.

The ARS-4 is pre-programmed at the factory for universal, "out-of-the-box" operation with most batteries. Built-in selectable programs for Deep-Cycle Lead Acid, AGM, Gel and Optima battery types are also available. Manual equalization, required for some battery types, is also available. The ARS-4 offers the ability to monitor and respond to alternator over-temperature conditions, when combined with optional alternator temperature sensor (MC-TS-A).



II. INSTALLATION

1. Mount the regulator in a dry, well-ventilated place, away from areas of excess heat and/or vibration. Avoid locations where regulator or wiring connections could be exposed to sprayed water or coolant.
2. If not pre-connected at the factory, attach the inline, fourplex plug to the regulator (see Figure 1). Connect the second ground wire (**BLACK**) to the Data Ground terminal. See Figure 4 on Page 2 for location.
3. The **BROWN** (ignition) wire activates the regulator. Attach the **BROWN** wire to a switched +12VDC source. The ignition switch or an independent (ungrounded) oil pressure switch are both acceptable connection points. A toggle switch may be added to this circuit to shut down the alternator manually when increased propulsion is needed.
4. Attach the **RED** wire in a location where it will sense the battery being charged. Likely connections include: 1) at the alternator's positive output, 2) at the common side of a battery selector switch (multi-battery banks), or 3) at the positive battery terminal (single battery bank). **WHEN USING A BATTERY ISOLATOR, THE RED SENSE WIRE MUST BE CONNECTED ON THE BATTERY SIDE OF THE ISOLATOR**, at the terminal supplying charging current to the larger battery bank.

If using a dual-output alternator, the RED wire must connect to one of the alternator output posts. If battery banks are unequal in size, connect at the larger battery bank. If the smaller battery shows signs of overcharging, move the RED wire to the alternator post supplying the smaller battery. The RED wire carries up to 6 amps and is equipped with a built-in 10-amp "mini" fuse and holder. If lengthening of the RED wire beyond eight feet is necessary, increase wire size to 12-gauge.

CAUTION

The following instructions are intended for use by experienced marine electrical installers. If you are not experienced at installing electrical system components, we recommend the use of a qualified marine electrical technician.

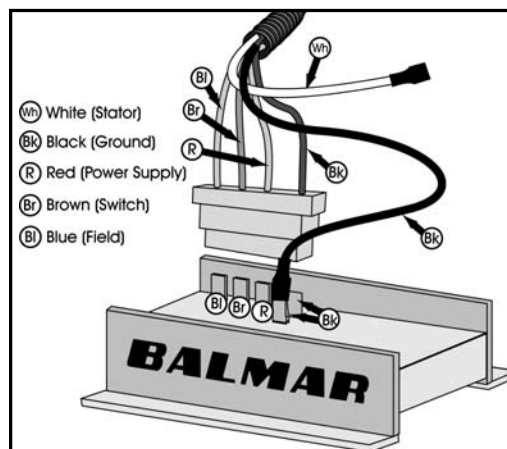

Figure 1 - Regulator wiring harness.

TABLE OF CONTENTS

I. Introduction	V. Advanced Programming	VIII. Equalization Voltage	XI. Troubleshooting
II. Installation	VI. System Voltage Adjustment	IX. Equalization Time	XII. Warranty
III. Operation	VII. System Time Adjustment	X. System Wiring Diagrams	

BALMAR® 19009 61st Ave. NE #4, Arlington, WA 98223

Phone: 360-435-6100 Fax: 360-435-3210 E-Mail: balmar@balmar.net Web: <http://www.balmar.net>

© Copyright 2001 Ballard Commercial Industries (BALMAR) - Reproduction of the materials included in this manual without the express written permission of Balmar is forbidden. See the "Manuals" section of our website for updates and additional information regarding these and other Balmar products. Revised October, 2001

II. INSTALLATION (CONTINUED)

- Connect the two **BLACK** ground wires at the preferred ground at the rear of the alternator (see Figure 2 for typical alternator ground connection).
- Connect duplex plug with **BLUE** and **WHITE** wires to the alternator. Some alternators may require ring terminal connections. If your alternator doesn't provide for a plug connection, see your alternator manual for installation instructions.

If your system utilizes a mechanical tachometer, the stator wire will not be used. **DO NOT CONNECT THE STATOR WIRE TO THE REGULATOR UNDER THAT CIRCUMSTANCE.**

- Attach optional Alternator Temp Sensor to the Alternator Temp Sensor terminals shown in Figure 5. **OBSERVE POLARITY.** Attach sensor to alternator case as shown in Figure 3.

Installing a toggle switch between the positive and negative wires of the Alternator Temperature Sensor cable allows you to reduce alternator output and horsepower load by 50% (Small Engine Mode).

- The Dash Lamp terminal provides a circuit for dash mounted visual or audible system warnings. Terminal output is 500Mil-Amps (0.50A) negative when activated by low voltage (12.8V), high voltage (1V over bulk), or high alternator temp (225°F). Typical installation would include an incandescent, LED or audible alarm connected, at one side, to a source of 12-volt positive and the second terminal connected to the dash lamp circuit at the regulator. When a condition matching those mentioned above occurs, the lamp circuit goes to ground, completing the circuit and activating the alarm.

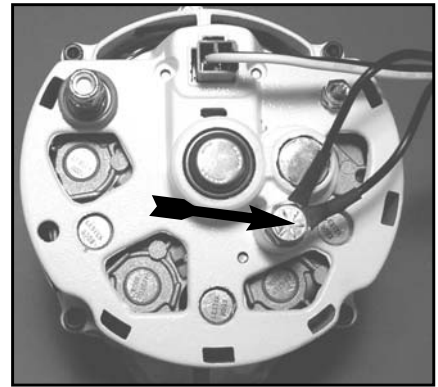

Figure 2 - Ground attachment.

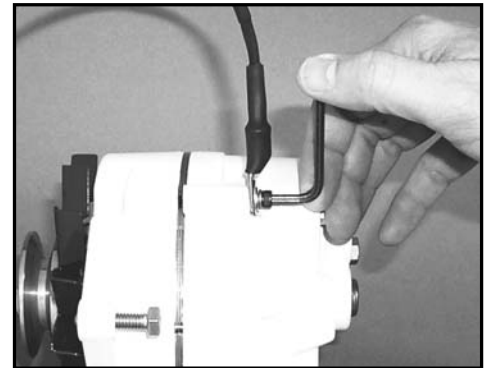

Figure 3 - Optional Alternator Temperature Sensor.

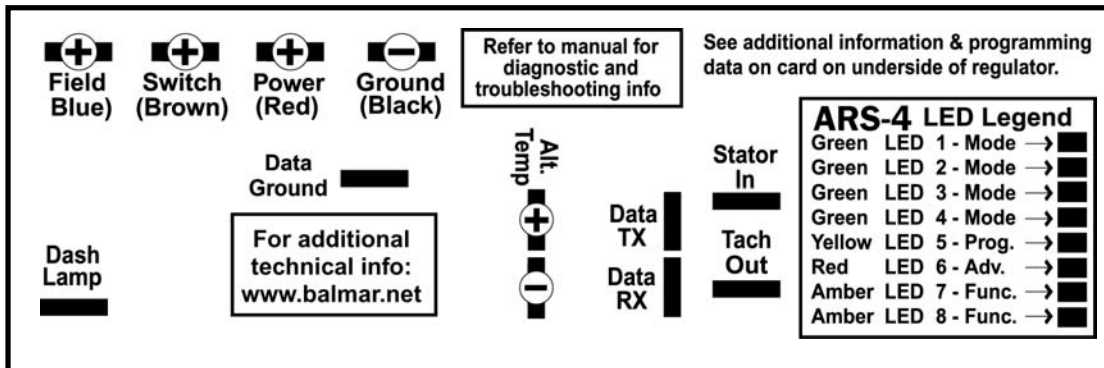

Figure 4 - Regulator terminal layout.

Primary Program Settings	PRG-1 Universal Factory Program	PRG-2 Deep Cycle Flooded Lead Acid	PRG-3 Gel Cell	PRG-4 Absorbed Glass Mat (AGM)	PRG-5 Optima Spiral Wound
Mode					
Start Delay (Seconds)	45	45	45	45	45
Ramp Up (Seconds)	60	60	60	60	60
Bulk Voltage (Max)	14.1	14.6	14.1	14.4	14.6
Bulk Time (Minimum)	36 min.	36 min.	36 min.	36 min.	36 min.
Absorption Voltage	13.9	14.4	13.9	14.2	14.4
Absorption Time (Minimum)	120 min.	120 min.	120 min.	120 min.	120 min.
Float Voltage	13.4	13.4	13.7	13.4	13.4
Float Time (Maximum)	6 hr.	6 hr.	6 hr.	6 hr.	6 hr.
High Voltage Alarm	15.2	15.6	15.1	15.4	15.6
Low Voltage Alarm	12.8	12.8	12.8	12.8	12.8
Max Battery Temperature	125°F/52°C	125°F/52°C	125°F/52°C	125°F/52°C	125°F/52°C
Max Alternator Temperature	225°F/107°C	225°F/107°C	225°F/107°C	225°F/107°C	225°F/107°C
Equalization	Yes	Yes	No	Consult Mfg.	Consult Mfg.

Figure 5 - Preset program values. Voltages may vary by +/- 3% from values shown.

III. OPERATION

Once the regulator is properly installed and connected to the rest of the charging system, it is ready to use. During operation, a bank of eight (8) color-coded LED lights will be illuminated to provide programming, mode, diagnostic and advisory information. At start-up, all eight LED lights will illuminate for approximately three seconds (Figure 6). Arrows indicate illuminated LEDs.

The initial display will be followed by a display which indicates battery program type (Figure 7). Out of the box, this display will indicate that the regulator is set in Universal Factory Program mode (indicated by a single green LED furthest from amber LED). Two green LEDs indicate Flooded Deep Cycle. Three green LEDs indicate Gel. Four green LEDs indicate Absorbed Glass Mat (AGM) battery. A single green LED closest to the illuminated amber LED indicates Optima battery setting. See **Figure 10** for illustration of program settings as indicated at start up.

The display will then cycle through the various charging stages (Figure 8). Single green LED furthest from the amber LED indicates 45-second start delay. Two illuminated green LEDs indicate soft ramp and bulk charging stage. Three illuminated green LEDs indicate absorption stage. Four illuminated green LEDs indicate float stage. See **Figure 9** for illustration of charging stages as indicated by the ARS-4 display during normal start-up operation.

During normal operation, the regulator will delay alternator start-up for 45 seconds to allow belts to seat and engine lubrication to occur. After the initial start delay, the regulator will ramp to charging voltage over a one-minute period.

Once bulk charging voltage is reached, the regulator will remain in the bulk stage for a minimum of 36 minutes. At the end of the 36-minute period, the regulator will compare actual battery voltage with target voltage (based on battery type) and determine whether to advance to absorption stage, or add additional 6-minute increments at bulk voltage until target voltage is reached.

Once in absorption stage, the regulator will remain at absorption voltage for a minimum of 120 minutes. Additional 6-minute increments will be added thereafter until target voltage is attained. Regulator will remain in float stage for a minimum of six hours, after which, it will cycle back to absorption stage for a minimum of 36-minutes. This cycle will continue throughout engine operation.

NOTE: THE REGULATOR WILL AUTOMATICALLY RETURN TO THE BEGINNING OF THE CHARGING PROGRAM IF THE ENGINE IS SHUT DOWN AND RE-STARTED.

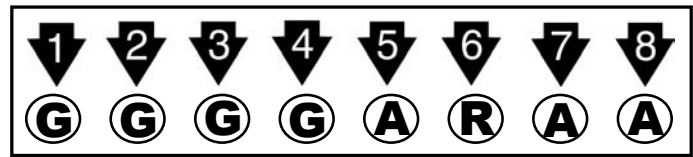

Figure 6 - Indicates system start-up.

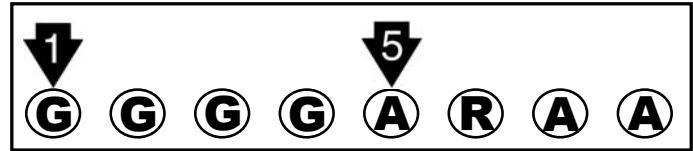

Figure 7 - Indicates preset program. (Program #1 - Universal factory program shown.)

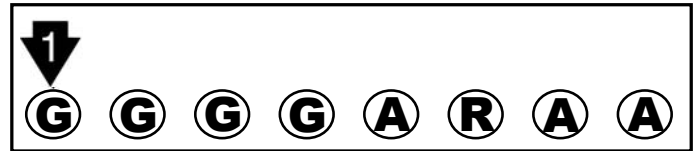

Figure 8 - Indicates charging stage. (Start delay shown.)

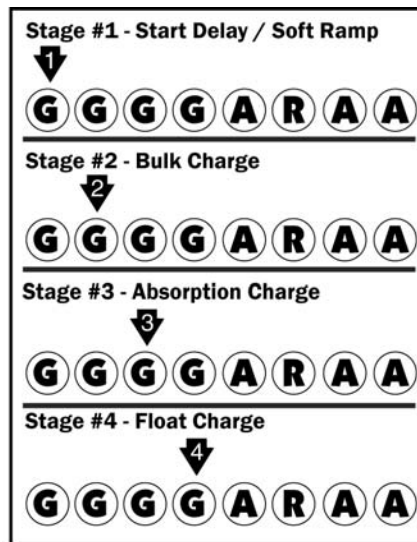

Figure 9 - Stages of charge as shown during normal operation.

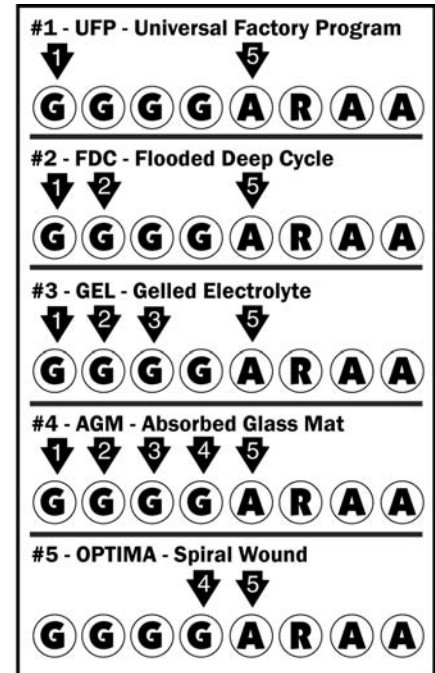

Figure 10 - Preset battery programs as shown during start up.

IV. BASIC PROGRAMMING

ARS-4 regulators are factory preset for universal, “plug-and-play” operation with most battery types. In addition to the default factory program, both models feature selectable programs for Deep-Cycle flooded, AGM, Gel and Optima battery types. (A list of detailed voltage and time values for the various presets is available on the **Page 2**, see Figure 4.) A magnetic reed switch, located beside the first green LED enables user adjustment. The switch works in two specific actions, as described in the box at right.

To select a program for your battery type:

1. Turn ignition key to it's ON position. Allow the regulator to cycle through the 45-second start delay and into the ramp-up/bulk stage (indicated by the two illuminated green LEDs).
2. Using the supplied magnetic screwdriver (as shown in Figure 11), Activate-Hold as discussed in the shaded box below. The #5 amber light and #6 flashing red light will illuminate to indicate switch activation (Figure 12).

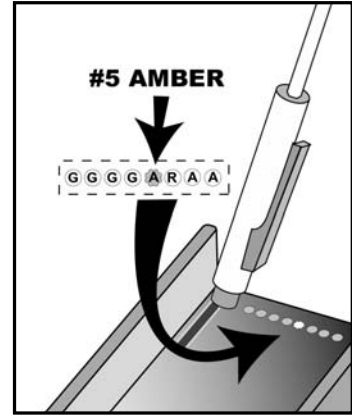

Figure 11 - Magnetic reed switch / LED location.

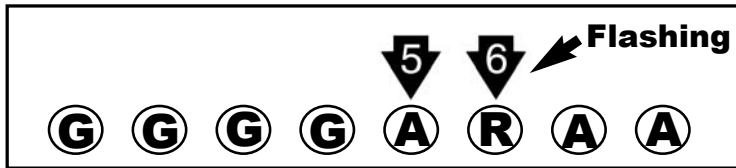

Figure 12 - Indicates magnetic switch is activated.

NOTE: The cycle speed for the display is five seconds. The regulator cycles at this rate to ensure adequate time to read LED codes and make adjustments.

3. The red LED will stop flashing and the #7 amber light will illuminate shortly thereafter to indicate the battery preset program mode is engaged (Figure 13).
4. As you continue to hold, the green lights on the left half of the LED display will be illuminated one-by-one to indicate battery type. The first green LED on the left will indicate Program 1 (Universal Factory Program). As you continue to hold the magnet to the switch, the display will cycle to the first two green LEDs (indicating Program 2 - Deep Cycle), three green LEDs (indicating Program 3 - Gel), four green LEDs (indicating Program 4 - AGM), or a single green LED closest to amber LED (indicating Program 5 - Optima). See **Figure 13** at right.
5. When the desired preset program is indicated, release the reed switch by removing your magnetic tool from the switch. Once a preset has been selected and the switch has been deactivated, the #5 amber light will go out, indicating that the switch has been deactivated. The green LED lights will remain for several second before going out (Figure 12).
6. Once the green lights have gone out, you may change your selection by re-applying the magnet to the switch. The program choices will scroll in reverse order. Note: Keep in mind that the display will stop scrolling once it reaches selection one or five (depending on whether you are ascending or descending in the program mode). To change the direction of scroll, release the switch, wait for the green lights to go out, and re-apply the magnet. The display will scroll in the opposite direction.

7. If the switch is not re-activated for several seconds, the #7 amber LED will flash to indicated that the program changes have been saved and the display will return to the “basic” mode as described in Section III.

‘ACTIVATE-RELEASE’ Refers to the activation and immediate deactivation of the switch by lowering the supplied magnetic screwdriver on the upper corner of the switch, and immediately deactivating the switch by removing the magnet from the switch.

‘ACTIVATE-HOLD-RELEASE’ Used primarily during user programming, this action requires holding the magnet to the switch until desired values are shown on the display. Once the desired setting is reached, the magnet is removed to deactivate the switch.

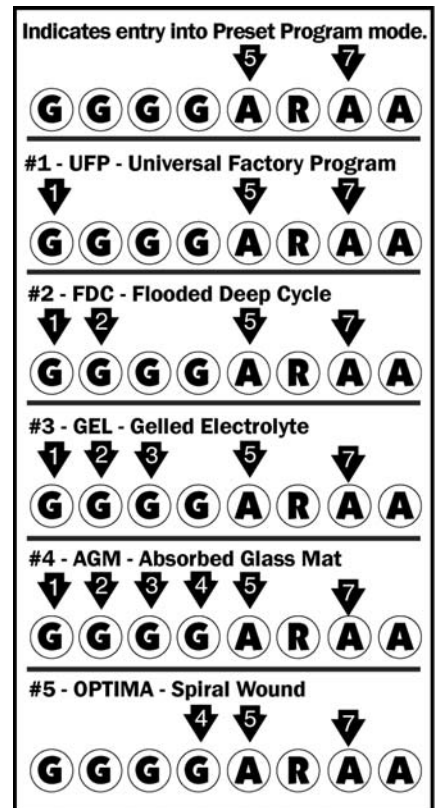

Figure 13 - Indicates preset program adjustment for specific battery types.

V. ADVANCED PROGRAMMING

Advanced Programming provides the ability to modify factory preset programs to meet specific charging needs. Advanced programming includes system voltage adjustment, system time adjustment, and equalization (time and voltage) adjustment. (Equalization is only suggested for batteries noted as “equalization friendly” in Figure 5 on Page 2). Consult your battery manufacturer for equalization time and voltage recommendations.

Equalization must be initiated through the advanced programming mode. It is NOT a standard mode of operation. Both EQ time and voltage must be set for equalization to occur. Equalization will occur immediately after the program has been saved into memory. **EQUALIZATION VALUES MUST BE SET WHILE ENGINE IS RUNNING.**

Once equalization is complete, the regulator will return to its preset program mode. NOTE: Advanced Programming modifications can be removed from the regulator's memory by reselecting the original program for your battery type. NOTE #2: The Advanced Programming Mode will cycle three times before saving new settings to memory. To enter to Advanced programming mode:

1. ACTIVATE-HOLD the magnetic reed switch. LED #5 will illuminate and LED #6 will flash several times (Figure 14).
2. Continue holding switch. LED #6 stops flashing, then LED #7 illuminates. This indicates the regulator has entered the program mode. RELEASE the switch AS SOON AS THE #7 AMBER LAMP IS ILLUMINATED, before the green “preset program” lights illuminate.
3. Once the switch is released, the #5 amber LED will go out. The #7 amber LED will remain for several seconds and will be replaced by the #8 amber LED, indicating that the regulator is in the System Voltage Adjustment mode

THE DISPLAY WILL SCROLL THREE TIMES THROUGH ALL OF THE ADVANCED PROGRAMMING MODES [SYSTEM VOLTAGE, SYSTEM TIME, EQ VOLTAGE, AND EQ TIME]. YOU MAY WAIT UNTIL THE DESIRED ADJUSTMENT MODE IS REACHED BEFORE ACTIVATING THE SWITCH.

VI. SYSTEM VOLTAGE ADJUSTMENT

The Voltage Adjustment mode increases or decreases the voltage values built into the preset programs based on battery type. Note: Changes in charging voltages affect ALL stages of the charging program. Keep in mind that the display has been programmed to provide approximately five seconds between value changes. This time period is provided to ensure correct adjustments. To adjust system voltage values:

1. When the LED indicates entry into the system voltage mode, indicated by the #8 amber light, ACTIVATE-HOLD the switch with your magnetic screwdriver. The display will begin to cycle up through the values shown in **Figure 15**. NOTE: To reverse scrolling direction, release the switch, wait until the green lights turn off, and re-activate and hold the switch to cycle the opposite direction.
2. When the display indicates your desired voltage adjustment, RELEASE the switch.
3. After several seconds, the green indicator lights will turn off.
4. If no changes are made to your selection, the #8 amber light will flash once, indicating that your selection has been accepted. The display will advance to the System Time Adjustment mode.

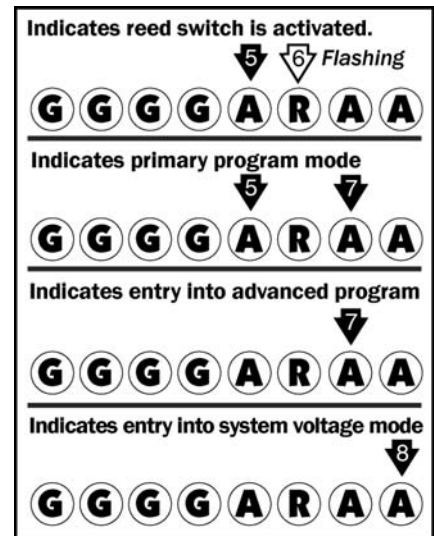

Figure 14 - LED display protocol indicating entry into advanced programming mode.

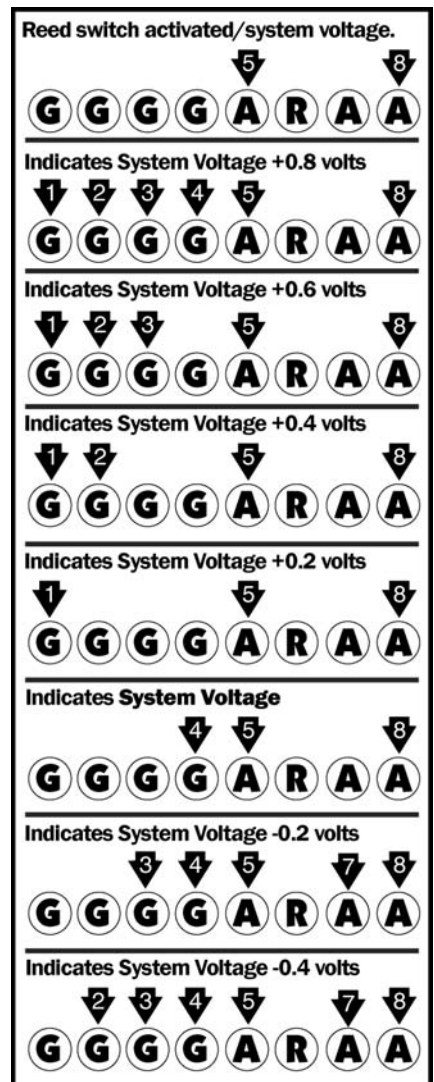

Figure 15 - LED display indicating advanced voltage adjustment.

VII. SYSTEM TIME ADJUSTMENT

The System Time Adjustment enables you to modify charging time values to meet your battery bank's specific charging needs. Keep in mind, changes in charging times affect ALL charging stages. To modify charging time values:

1. When the LED display indicates entry into the system time adjustment mode, as shown in **Figure 16**, ACTIVATE-HOLD the switch with your magnet. The display will cycle up through the values shown in Figure 16. NOTE: To reverse scrolling direction, release the switch, wait until the green lights turn off, and re-activate and hold the switch to cycle the opposite direction. Keep in mind that the display has been programmed to provide approximately five seconds between value changes.
2. When the display indicates your desired system time adjustment, release the switch.
3. After several seconds, the green LEDs will turn off.
4. If no changes are made to your selection, the #7 and #8 (amber) lights will flash once, indicating that your selection has been accepted. The display will advance to the Equalization Voltage Adjustment mode.

VIII. EQUALIZATION VOLTAGE

The onset of sulfation can be lessened in some battery types by periodic introduction of elevated voltage to the battery. See **Figure 4** on Page 2 to determine if your battery type will benefit from equalization. Voltage values are based on system voltages determined by your preset program. CAUTION: Consult with your battery manufacturer for recommended equalization time and voltage. Both time and voltage values must be set for equalization to occur.

NOTE: EQUALIZATION TIME AND VOLTAGE MUST BE SET WITH THE ENGINE RUNNING. ONCE EQUALIZATION HAS BEGUN, THE DISPLAY WILL SHOW ALL FOUR GREEN LIGHTS AND THE #6 RED LIGHT.

1. When the LED indicates entry into the EQ Voltage mode, as shown in **Figure 17**, ACTIVATE-HOLD the switch with your magnet. The display will show system voltage. When you activate the switch, the display will scroll up through the voltage values shown in **Figure 17**. Reversing the process will scroll downward.
2. When the display indicates your desired EQ voltage value, RELEASE the switch.
3. After several seconds, the green indicator lights will turn off.
4. If no changes are made to your selection, the #6 red and #7 amber lights will flash once, indicating that your selection has been accepted. The display will advance to the Equalization Time Adjustment mode.

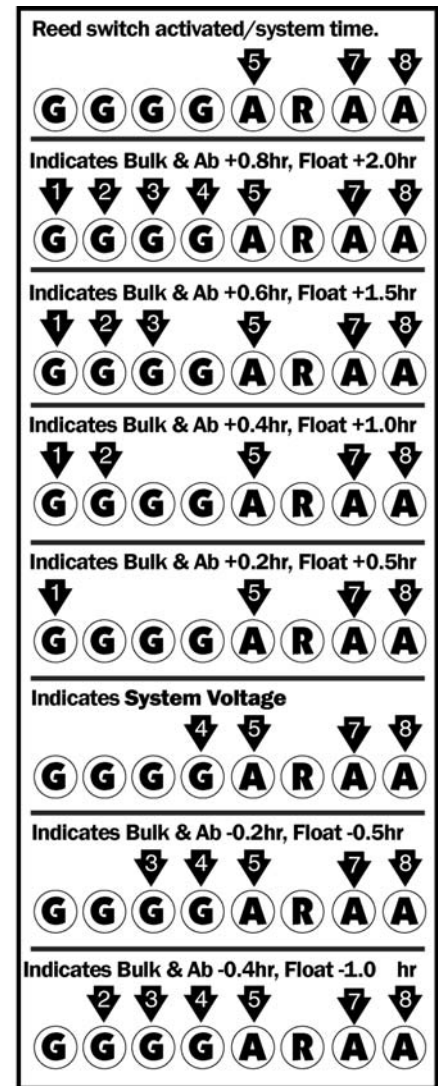

Figure 16 - LED display indicating advanced system time adjustment.

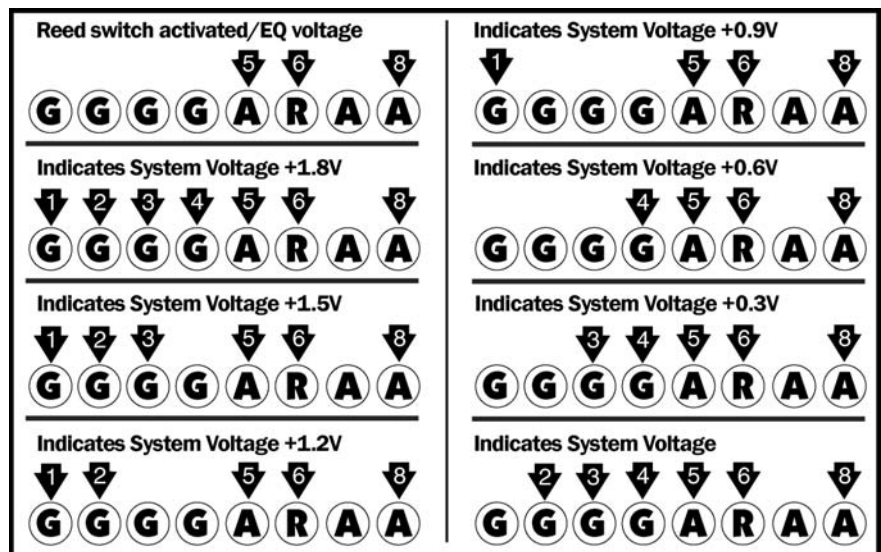

Figure 17 - LED display indicating advanced EQ voltage adjustment.

IX. EQUALIZATION TIME

The final mode in the Advanced Programming cycle is Equalization Time Adjustment. To change the duration of EQ time:

1. When the LED display indicates entry into the Equalization Time Adjustment mode, as shown in **Figure 18**, ACTIVATE-HOLD the switch with your magnet. The display will show the system default time. Release the switch, wait for the green light to go out, and re-activate/hold switch. Equalization Time Adjustment values will scroll through the values shown in **Figure 18**. Reversing the process will scroll downward.
2. When the display indicates your desired EQ time value, release the switch.
3. After several seconds, the green indicator lights will turn off.
4. If no changes are made to your selection, the lights will flash once, indicating that your selection has been accepted. The Advanced Programming display will cycle two more times. If no other changes are made to your programming selections, the changes will be saved. A flashing #8 amber LED at the end of the final cycle indicates that your Advanced Programming selections have been saved.
5. Equalization will occur immediately after the EQ time and voltage values have been saved into memory. Once equalization is completed, the regulator will return to regular charge mode governed by your preset battery program. **CAUTION:** Contact your battery manufacturer for recommended EQ time and voltage values. Do not attempt equalization unless recommended by the battery manufacturer.

ADVANCED PROGRAMMING FOR SYSTEM VOLTAGE AND SYSTEM TIME FUNCTIONS WILL REMAIN IN THE REGULATOR'S MEMORY UNTIL THEY ARE MODIFIED WITHIN ADVANCED PROGRAMMING, OR UNTIL THE PRESET PROGRAM FOR BATTERY TYPE IS RE-SELECTED.

CAUTION: EQUALIZATION VOLTAGE MAY EXCEED THE LIMITS OF SOME VOLTAGE SENSITIVE ONBOARD ELECTRONICS. EXTREME CARE SHOULD BE EXERCISED TO ENSURE THAT ANY SENSITIVE EQUIPMENT IS TURNED OFF AND/OR DISCONNECTED FROM YOUR ELECTRICAL SYSTEM BEFORE EQUALIZATION TAKES PLACE.

X. WARNING / ADVISORY CODES

ARS-4 multi-stage regulators are equipped to provide diagnostic information via the LED display. To access diagnostic data:

1. After the basic display mode (see Section III) has cycled through its initial start-up, ACTIVATE-RELEASE the magnetic switch with your magnetic tool.
2. The #6 red LED will begin to flash as the regulator scans through its diagnostic circuit.
3. When the regulator senses a situation requiring attention, the flashing #6 red LED will alternate with specific groupings of green LED lights.
4. Each LED grouping will correspond to a condition described in **Figure 19**. Each code will be displayed for several seconds, at which point, the regulator will continue to search for additional conditions.
5. After all warning/advisory codes are displayed, the regulator will return to basic display mode.

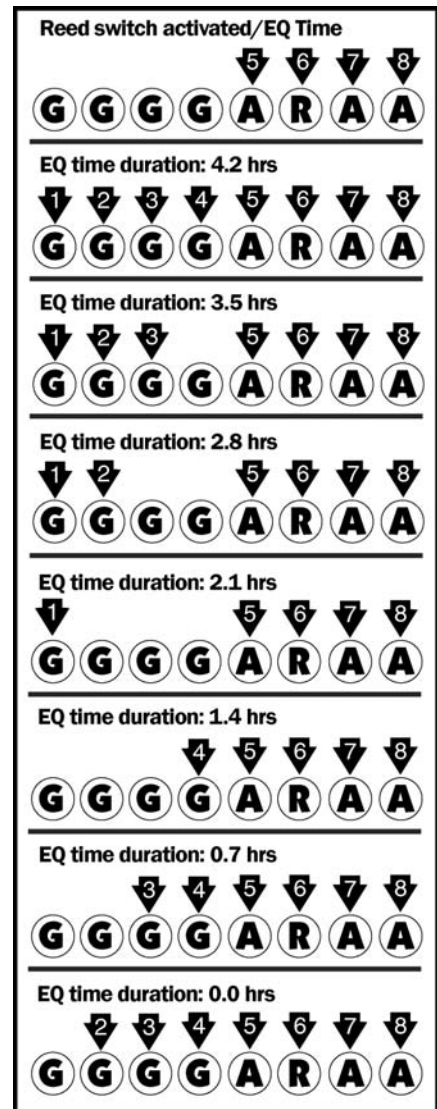

Figure 18 - LED display indicating advanced EQ time adjustment.

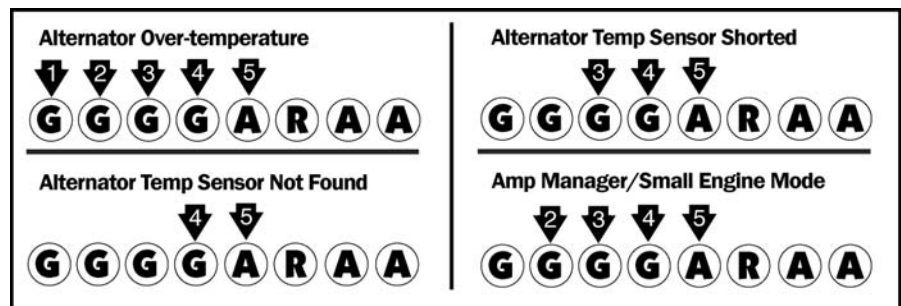
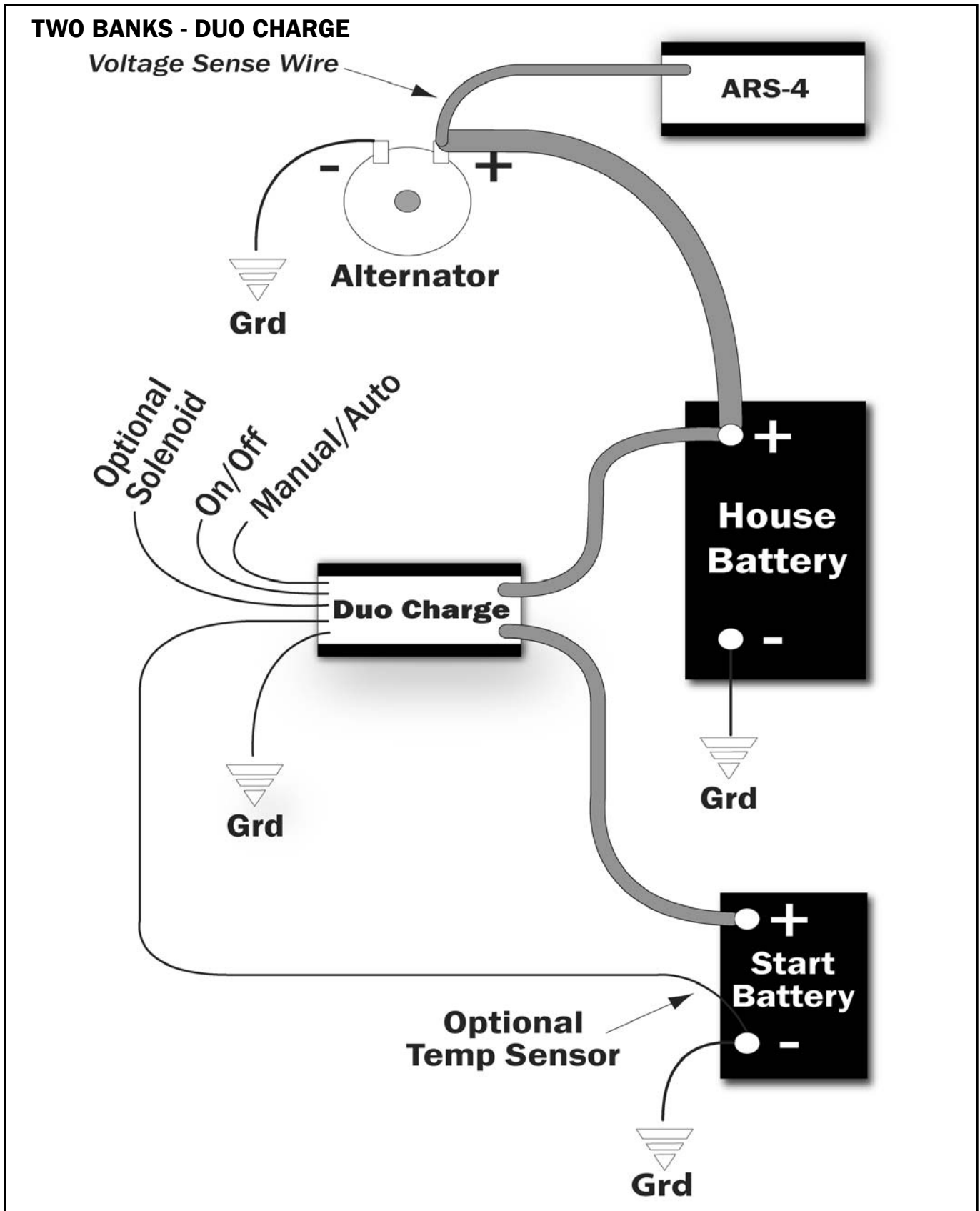

Figure 19 - LED display indicating error/advisory codes.

XI. SUGGESTED SYSTEM WIRING

Optimal regulator operation may depend on wiring layout - based on battery configuration and method of battery separation used. The diagrams on Pages 8 & 9 illustrate some common recommended wiring layouts.



SINGLE OUTPUT - SWITCH

Voltage Sense Wire

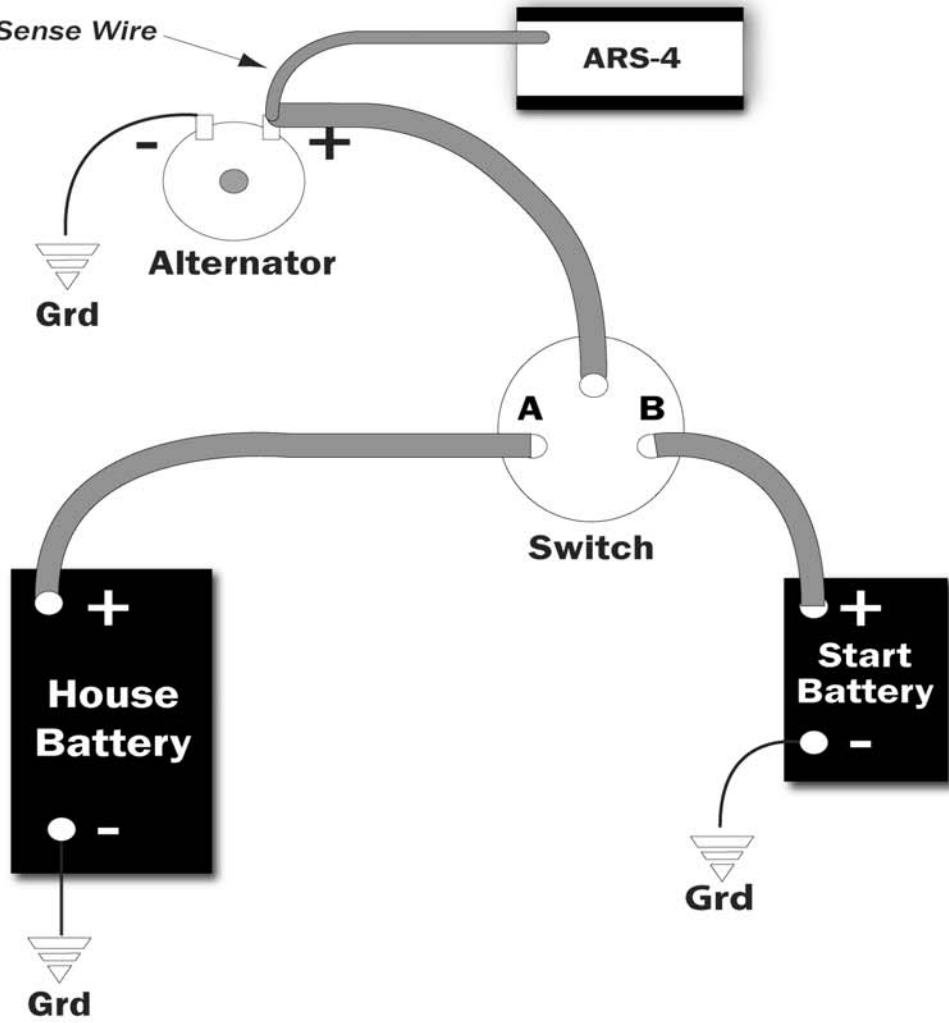

DUAL OUTPUT

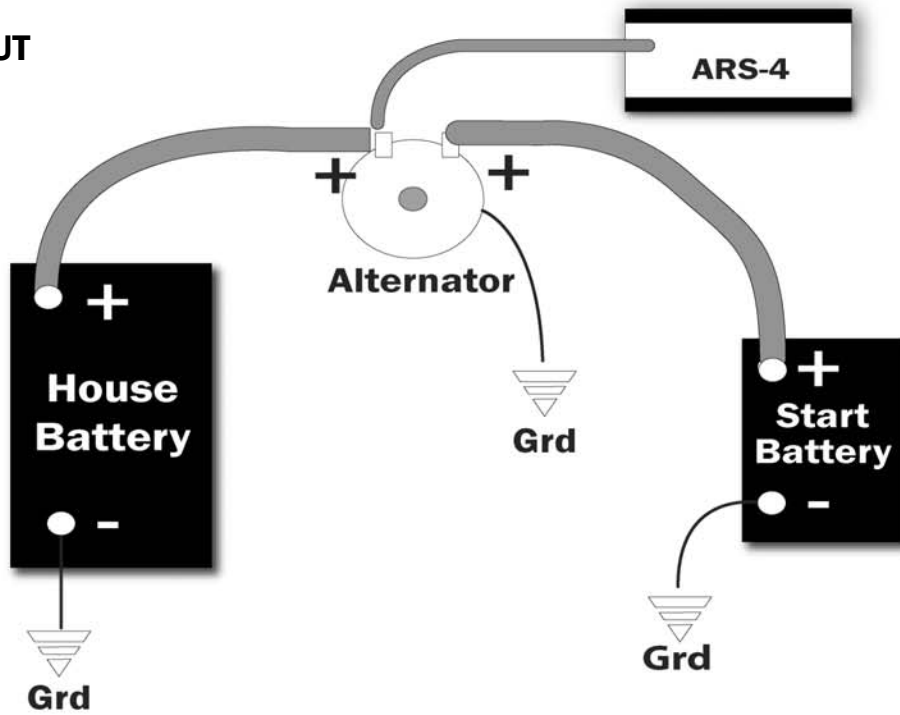

XII. ALTERNATOR AND REGULATOR TROUBLESHOOTING

Determining the causes of failures in an electrical system is a “step by step” process. We recommend that you inspect and clean all system electrical connections before you begin your search to determine if the failure can be attributed to one of the two main components of your charging system: the alternator, and/or the voltage regulator.

Most charging system problems will be corrected by performing the following steps.

1. Remove and clean all charging system electrical connections from the alternator through the batteries (this includes the ground side). Also, check the voltage regulator’s harness for resistance. Wires and terminals can and will become corroded and need to be cleaned or replaced.
2. Charge all batteries to their proper fully charged state and determine if they are serviceable. If your batteries are flooded-type, use your hydrometer to determine their condition.
3. Check and tighten alternator belt. If the belt shows signs of wear or damage, now is an ideal time for replacement. Always replace existing belts with the finest quality replacements available.

After determining that your batteries and wiring are in suitable condition, use the following tests to determine if charging problems are a result of a faulty alternator or regulator. The following tests provide an opportunity to isolate the alternator, regulator and wiring harness in order to determine which component may be malfunctioning. In order to preform these tests, you will need an independent multimeter (preferably a digital type). In an emergency, a 12V light bulb can be used to help determine if power or working grounds exist. An amp meter and a battery hydrometer with a thermometer are also helpful diagnostic tools.

ALTERNATOR /REGULATOR FIELD TESTS

Test A - The alternator and regulator can be tested for function by determining if a magnetic field exists at the alternator’s pulley shaft or rear bearing. To test:

1. With the ignition in the OFF position, place the head of a steel screwdriver near the nut on the pulley shaft or near the rear bearing of the alternator. There should be no evidence of a magnetic field pulling the screwdriver toward the alternator.
2. Engage the ignition, without starting the engine, to activate the voltage regulator. If an oil pressure switch is used, a jumper across the switch will activate the regulator.
3. After allowing time for the regulator’s start-up delay, place the head of a steel screwdriver near the nut on the pulley shaft or near the rear bearing of the alternator. There should be evidence of a magnetic field pulling the screwdriver toward the alternator. If a magnetic field is present, the voltage regulator, alternator brushes and rotor are likely to be working properly. If the system is not charging, remove the alternator and have it inspected by a qualified alternator shop.

Test B - If there is little or no magnetic pull at the pulley shaft or at the rear bearing, initiate the following test:

1. With the key off and the engine off, remove the large harness plug from the regulator.
2. Insert the end of a short length of electrical wire to the RED connector slot of the regulator harness and the other end of the wire to the BLUE connector slot. See figure at right. This bypasses the regulator and tests the alternator and the harness.
3. Using your steel screwdriver, inspect for a magnetic field as described above.
4. With your voltmeter, check for voltage on the blue wire at the alternator. If voltage does not exist, the harness may be at fault. If voltage does exist at the harness, but charging is not occurring, the alternator is likely to be malfunctioning.

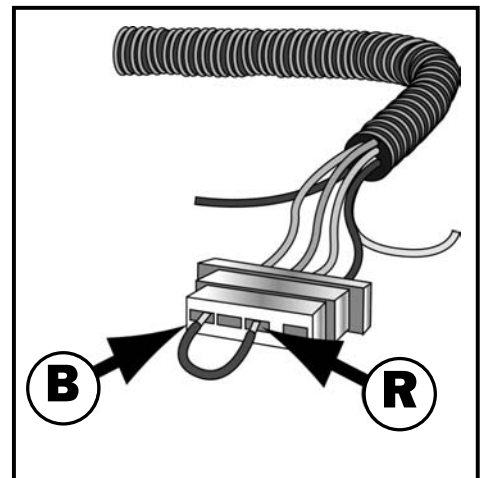

If a magnetic field is present. Both harness and alternator brushes and rotor appear to be working properly. If no magnetic field is present, proceed with the next test.

Test C - Testing the actual output of the alternator is known as “Full Field Testing”. This can be accomplished by jumping a positive 12VDC current to the field terminal at the rear of the alternator. This test eliminates both the regulator and the harness, making it easier to isolate your investigation to the alternator. CAUTION: Ensure that all voltage sensitive equipment is turned off prior to starting the engine. Voltage is unregulated during this test and could damage sensitive electronics. DO NOT let the engine run any longer than necessary to detect charging.

To test the alternator:

1. Clip a jumper wire to the positive post of the alternator, or on the battery side of the isolator, if an isolator is in use. Use a SHIELDED alligator clip for post attachment. Unintentional contact between the alligator clip and the alternator case could result in damage to your electrical system.
2. Disconnect the field/stator plug from the rear of the alternator and attach the other end of the jumper wire to the alternator's Field terminal (F). Attach a female spade connector to the field end of the wire for a solid connection. CAUTION: Do not allow the wire to contact the case while it is attached to the positive post. The case is grounded and severe damage could occur.
3. The regulator is now bypassed. When the ignition is engaged and the motor is started, the voltage should rise and charging current should be present.
4. The motor should be run long enough to determine that charging voltage is present. Unregulated voltage can rise quickly. Do not allow extended unregulated charging to occur without carefully monitoring voltage levels.

If the alternator fails to generate voltage during field testing, a malfunction of the alternator is likely. Contact your local alternator repair shop or Balmar's technical service staff for recommendations.

VOLTAGE REGULATOR TEST

When you have inspected and repaired any wires and connections, inspected belts and replace as needed, and after you have determined that your batteries are properly charged, set your voltmeter to 12V and connect the voltmeter's negative lead to the BLACK ground wire at the regulator. Normally, connection is accomplished by inserting the negative lead alongside the ground wire in the regulator harness plug (see Figure 31) and the positive lead alongside the wire referred to in each specific test. With the voltmeter securely connected to the regulator's ground, test for voltage at the points listed below.

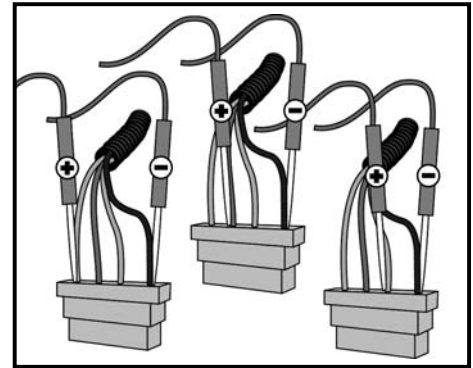

Figure 31 - Testing voltage at regulator.

1. With the ignition in the OFF position and your voltmeter's ground wire connected to the regulator's ground, check for voltage on the red (sensing), blue (field) and brown (ignition) wires in the regulator plug by inserting the positive lead of the voltmeter alongside each wire in the regulator harness plug. The voltmeter should read:

	Red Wire	Brown Wire	Blue Wire
Expected Reading	12 V *	0 V	0 V
Your Reading			

2. With the ignition in the ON position (engine not running) and your voltmeter's ground wire connected to the regulator's ground, check for voltage on the red (sensing), blue (field) and brown (ignition) wires in the regulator plug. The voltmeter should read:

	Red Wire	Brown Wire	Blue Wire
Expected Reading	12 V*	12 V	7 - 12 V
Your Reading			

3. With the ignition in the ON position (with engine running at 1,400 rpm fast idle) and your voltmeter's ground wire connected to the regulator's BLACK wire, check for voltage on the red (sensing), blue (field) and brown (ignition) wires in the regulator plug. The voltmeter should read:

	Red Wire	Brown Wire	Blue Wire
Expected Reading	12 - 14V**	12 V	3 - 11 V
Your Reading			

* 11.5 - 12.8 VDC battery voltage at rest (no charging occurring). If your batteries are isolated and your RED (sensing) wire shows voltages other than those shown above, make sure that the wire is connected on the "battery" side of the isolator. The RED wire must "see" the battery directly.

** 13.5 - 14.5 VDC battery voltage when charging.

If your readings differ substantially from the “Expected Readings” listed in the charts above, the regulator may be malfunctioning, or there may be a continuity problem. Contact our technical support staff at (360) 435-6100. Keep your recorded readings in the spaces provided below the “Expected Readings” so you can share them with the technical support person. If your readings match those listed in the charts, your regulator should be working correctly. Continue with tests below to determine if your alternator may be the source of charging difficulties. If the preceding tests do not prove the existence of a failure within the regulator or alternator, we recommend you contact a licensed marine electrician who can test your system for wiring and circuit damage or other system failures that could be responsible for charging difficulties. If you determine that repair service is necessary for either your alternator or regulator, please gather the following information before contacting our service technicians.

1. Model of alternator.
2. Model of voltage regulator.
3. Voltage readings on red, brown and blue wire at regulator with engine off, key on.
4. Voltage readings on red, brown and blue wire at regulator with engine running at a fast ideal 1400 rpm.

XII. LIMITED PRODUCT WARRANTY

BALMAR warrants to the original consumer/purchaser the product is free from any defects in material or workmanship for a period of one year from the date of purchase. If any such defect is discovered within the warranty period, BALMAR will replace the regulator free of charge, subject to verification of the defect or malfunction upon delivery or shipping prepaid to BALMAR.

This warranty DOES NOT apply to defects or physical damage resulting from abuse, neglect, accident, improper repair, alteration, modification, or unreasonable use of the products resulting in breakdown, cracked or broken cases nor are parts damaged by fire, water, freezing, collision, theft, explosion, rust, corrosion or items damaged in shipment in route to BALMAR for repair. BALMAR assumes no responsibility for consequential damage or loss or expense arising from these products or any labor required for service or repair.

BALMAR WILL NOT repair or be held responsible for any product sent without proper identification and return address or RA number clearly marked on the package. You must include proof of date and place of purchase (photocopy of purchase invoice) or we cannot be responsible for repairs or replacement. In order to expedite warranty claims more efficiently, BALMAR asks that prior to returning a defective product for repair, you call their customer service department for a warranty return authorization number .

If factory service is required, you can contact our BALMAR Customer Service Department Monday through Thursday, 7:30 AM to 5:30 PM, (PST)1-360-435-6100.

Material required for the repair or replacement for the defective part or product is to be supplied free of charge upon delivery of the defective regulator to BALMAR, 19009 61st Ave. NE, Arlington, WA 98223. Customer is responsible for all return transportation charges and any air or rush delivery expense. BALMAR reserves the right to determine whether to repair or replace defective components.

THE ABOVE LIMITATIONS MAY NOT APPLY TO YOU. SOME STATES DO NOT ALLOW LIMITATIONS ON HOW LONG AN IMPLIED WARRANTY LASTS. NO PERSON, AGENT, DEALER IS AUTHORIZED TO GIVE ANY WARRANTY.

BALMAR[®] 19009 61st Ave. NE, Arlington, WA 98223 Phone: 360-435-6100,

Fax: 360-435-3210 E-mail: balmar@balmar.net, Web: <http://www.balmar.net>

©2003 Ballard Commercial Industries, Inc. (BALMAR)

Pub.# BC-00004 - 6 - 03