

AT-Series Alternators

Designed for Recreational Applications

- 165A or 200A in a Small Case Package
- Up to 125A at Idle Speeds
- 25% More Efficient
- Dual Fan Cooling, High Airflow Frame
- Maximum RPM: 12,000
- Ideal for Large Battery Banks

AT (“Advanced Technology”) Series Alternators from Balmar bring together the latest innovations in alternator design to deliver incredible charging power in a compact, Marine-friendly package.

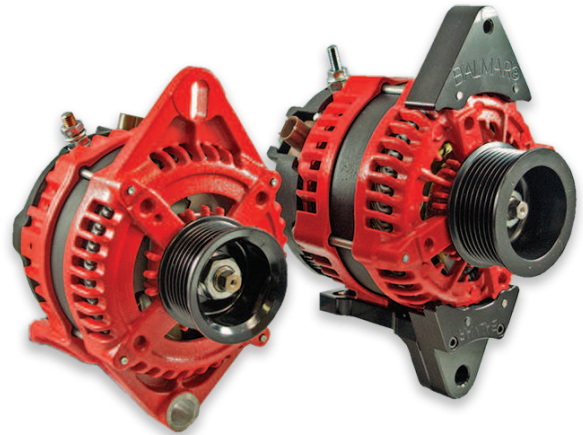

AT-Series Alternators feature a unique hairpin-wound stator design which uses densely wound square copper wire to generate exceptional output in the smallest possible area. Hairpin-wound stators feature 96 slots - compared to 36 slots in a traditional S-wound stator – allowing the hairpin-wound stator to develop superior electromagnetic energy and efficiency superior to other traditional stator designs.

AT-Series Alternators also feature a dozen 50A capacity, externally mounted avalanche diodes, dual internal fans, and massive heat sinking designed to ensure essential cooling under high load demands. Scaled to fit in most original position installations, AT-Series Alternators are available in all four common mounting styles. See the charts on pages 4 & 5 for complete alternator dimensions.

The AT Alternator may require a Tachometer Signal Stabilizer (Part No. 15-TSS) if your current tachometer is not adjustable. AT-Series Alternators should only be used in Dual Vee or Multi-Groove Serpentine belt configurations. Balmar’s growing range of Altmount Serpentine Pulley Conversion Kits support all AT-Series Alternators.

AT-Series Output	Power Take Off	Mounting	Individual Alternator Part Number ⁽¹⁾⁽³⁾	Alternator Kit with Max Charge Regulator ⁽²⁾	Altmount® Pulley Kit Required?
165 A	5.2 HP	1-2" Spindle	AT-SF-165-XX	AT-SF-165-XX-KIT	Yes, If DV or Serpentine is Not Present
		3.15" Saddle	AT-DF-165-XX	AT-DF-165-XX-KIT	
200 A	6.0 HP	1-2" Spindle	AT-SF-200-XX	AT-SF-200-XX-KIT	
		3.15" Saddle	AT-DF-200-XX	AT-DF-200-XX-KIT	
		4" Saddle	AT-DF4-200-XX	AT-DF4-200-XX-KIT	

(1) “XX” Pulley Designations: “DV” = 1/2” Dual Vee, “K6” = K6 Serpentine, “J10” = J10 Serpentine.
 (2) Kit Includes AT-Series Alternator, Max Charge Regulator (MC-614-H) and Temperature Sensors (MC-TS-A, MC-TS-B).
 (3) The AT-Series Alternator may require a Tachometer Signal Stabilizer (Part No. 15-TSS) if our current tach is not adjustable.

How to Select the Correct Balmar Charging System for Your Vessel

Step 1: Determine your Electrical Load

All your device loads and expected duty cycles will clarify your expected daily battery discharge requirements. Add a safety factor.

Step 2: Identify your Battery Bank Technology and Capacity

How many batteries are in your bank and what is the total storage capacity?
 What type of batteries are employed? (Different technologies require different charging programs)

Step 3: Select your Alternator Output

The correct charging load depends on the battery technology and capacity.
 For example, an AGM battery can accept a 40% charge load, so a 300Ah bank of AGMs can accept 120A of charging from the alternator. Therefore you could utilize a 120A alternator to charge your bank as quickly as possible.

Step 4: Identify the Alternator Mounting Style Present on your Engine

The most common mounting styles are shown to the right:		
(A) 1" Single Foot (Spindle Mount)	"Motorola Style"	Balmar AT-SF Series
(B) 2" Single Foot (Spindle Mount)	"Delco Style"	Balmar AT-SF Series
(C) 3.15" Dual Foot (Saddle Mount)	"Hitachi Style"	Balmar AT-DF Series
(D) 4" Dual Foot (Saddle Mount)	"J-180 Style"	Balmar AT-DF4 Series

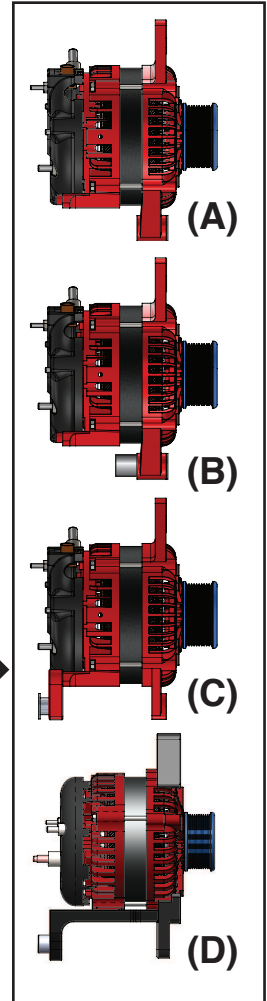

Step 5: Determine your Belt and Pulley Requirements

An AltMount® belt/pulley conversion kit may be required to handle your alternator Power Take-Off ("PTO") load.

Detailed toolsets for calculating loads and selecting the appropriate charging system for your vessel are available in the Balmar Catalog or at www.balmar.net

AT-Series Alternator Specifications

Alternator Style: Small Case, Positive Field Excitation (P-Type)	Positive Output: Threaded Stud Stud Dimensions: (AT-165: M6-1.0) (AT-200: M8-1.25)
Regulation: External P-Type (MC-614)	Lamp Output: D+ (low voltage / low current) Stud Dimensions: (AT-165: M6-1.0) (AT-200: M6-1.0)
Cooling: Dual Internal Fans	Grounding: Dedicated Terminal (Case Isolated) Stud Dimensions: M8 x 1.25"
Bearings: Sealed Bearings, Heavy Duty Radial (front & rear)	AC/Stator Output: 16 Poles. Stator Output Wire included in Pigtail Plug.
Case Construction: Ventilated Cast Aluminum High Impact Plastic Rear Cover	Internal Voltage Regulation: 14.1 Volts (12V systems) Internal Regulation to be Available in 2016
Finish: Red Powder Coat	Diodes +/-: 6 Positive, 6 Negative; 50A Rated
Tensioning Arm Mount: 0.88" (22.4mm) Vertical Slot	Low RPM Cut-In: 1,320 rpm Max Alternator RPM: 12,000 rpm
Mounting Foot Bore: AT-DF & AT-DF4-Series: 10mm AT-SF-Series 1 inch: 1/2", AT-SF-Series 2 inch: 3/8"	Normal Operating Temperature: 180 °F / 82° C Max Operating Temperature: 225° F / 108° C
Mounting Styles: AT-SF Series: 1" or 2" Single Foot (Spindle) AT-DF Series: 3.15" Dual Foot (Saddle) AT-DF4 Series: 4" Dual Foot (Saddle) - 200A Version Only	Ignition Protection Ratings: USCG Title 33, ISO J1187, CE, SAE 8846

AT-Series Output Curves

Alternator output is dependent on a number of factors: battery condition and capacity, wire size, engine horsepower and engine RPM, battery temperature and alternator temperature. Of these factors, alternator speed and temperatures are the most important. The following graph describes alternator output based on two temperature levels (ambient (26° C) and hot (90° C)). Test voltages are set at 13.5V.

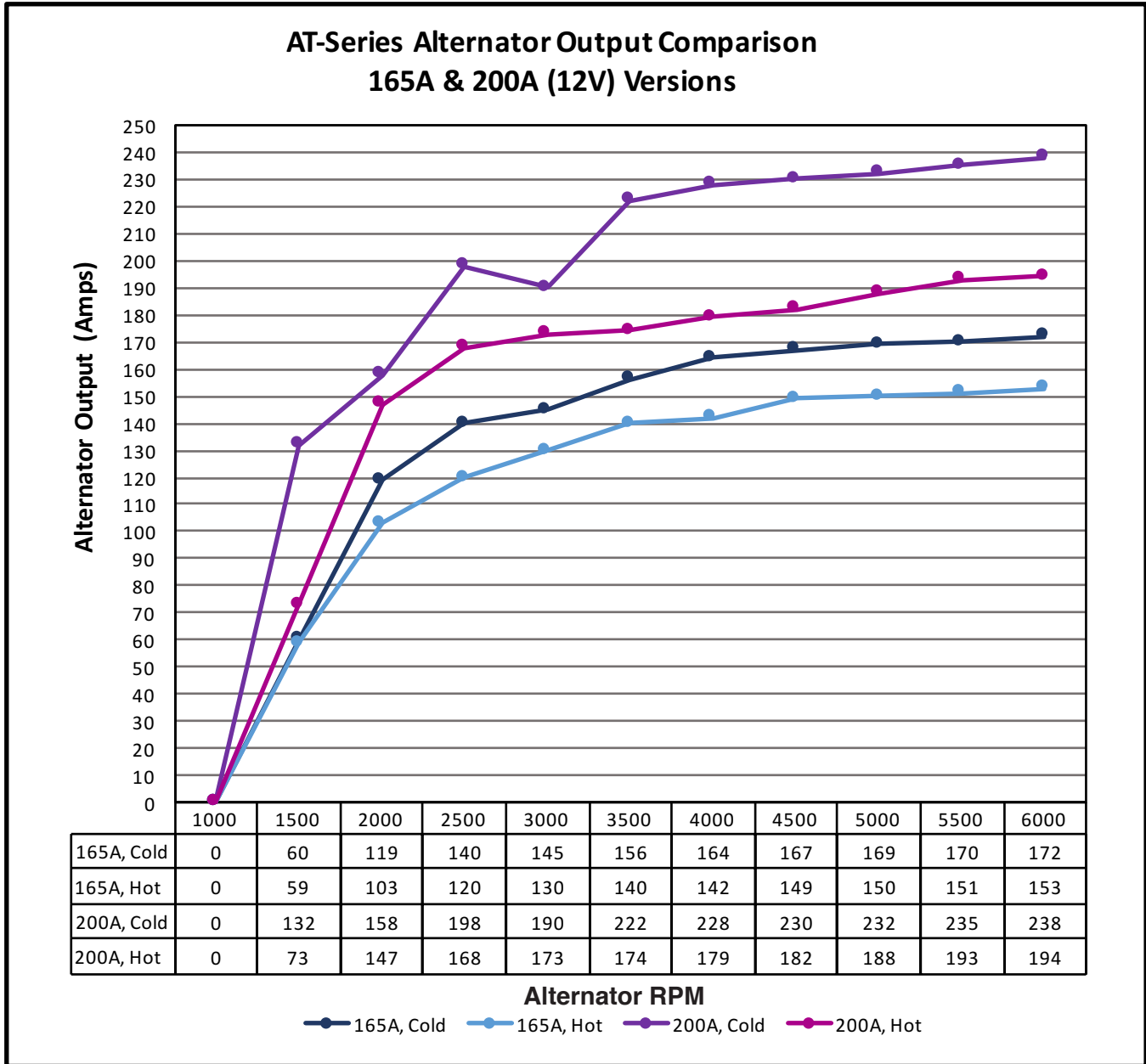

Balmar AT-Series Alternators and Charging Kits provide maximum charging power in a small case package suitable for installation in most small-to-medium sized diesel engines and most GM-based 4.3L to 8.1L gasoline engines.

Utilize the Balmar product configurator at www.balmar.net to locate a solution for your engine.

AT-165-Series Dimensions

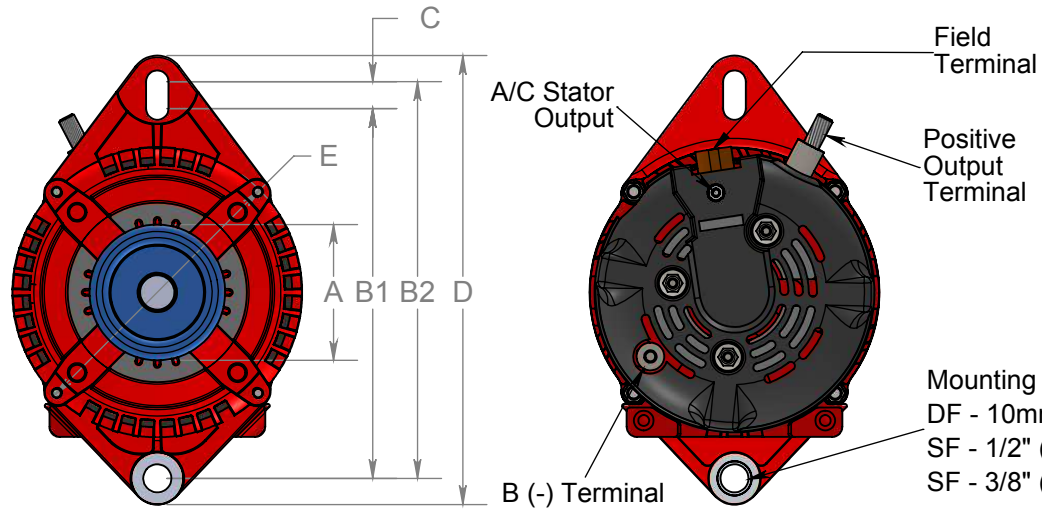

Mounting Foot Bore:
 DF - 10mm
 SF - 1/2" (1")
 SF - 3/8" (2")

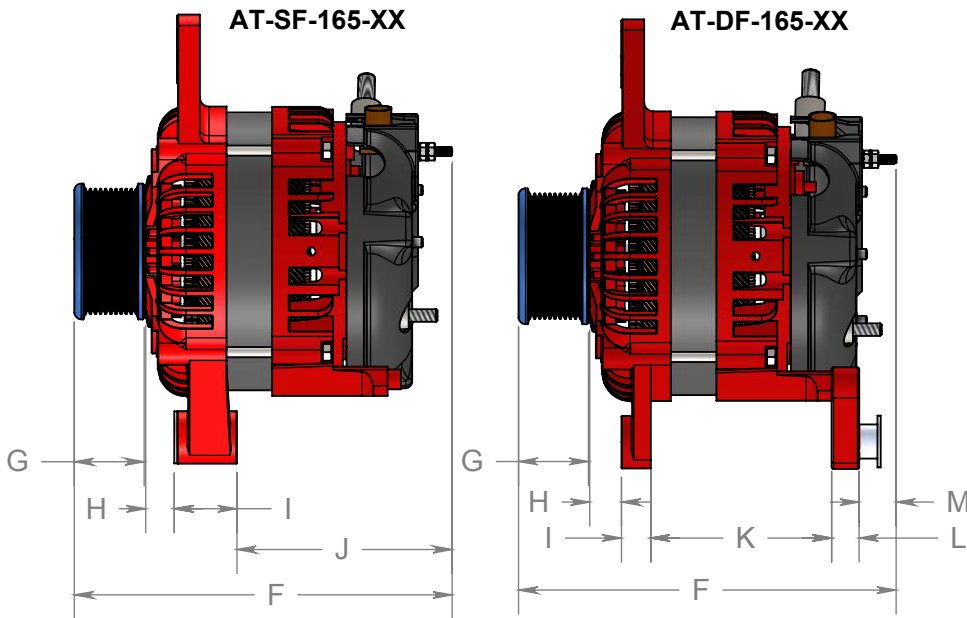

ITEM	DESCRIPTION	IN.	mm
A	Dual Vee (DV) Pulley Dia.	3.20	81
	K6 (Serpentine) Pulley Dia.	3.00	76
	J10 (Serpentine) Pulley Dia.	2.47	62
B1	Mounting Hole-to-Slot	6.74	171
B2	Mounting Hole-to-Slot	7.23	183
C	Slot Length (Bolt Centers)	.50	12
D	Over-all Height	8.18	208
E	Case Diameter	5.28	134
F	Over-all Length w/ DV Pulley	7.1	180
	Over-all Length w/ K6 Pulley	6.78	172
	Over-all Length w/ J10 Pulley	6.74	169

ITEM	DESCRIPTION	IN.	mm
G	DV Pulley Width	1.49	38
	K6 Pulley Width	1.18	30
	J10 Pulley Width	1.14	29
H	Case Front to Foot Front	.52	13
I	Foot Thickness (SF)	1.14	29
	Foot Thickness (DF)	.53	13
J	Foot to Stator Output	3.94	100
K	DF Saddle Width	3.30	84
L	Foot Thickness	.50	.12
M	Foot to Statot Output	.68	17

Dimensions are approximate and for reference only. Contact Balmar Technical Support if further details are required.

AT-200-Series Dimensions

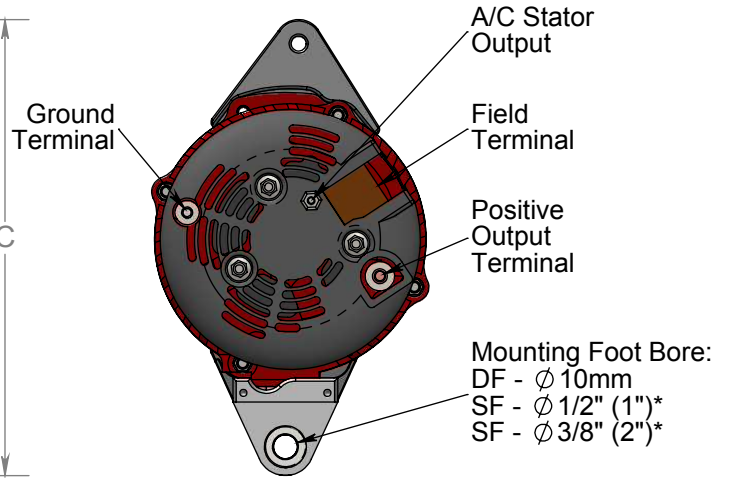
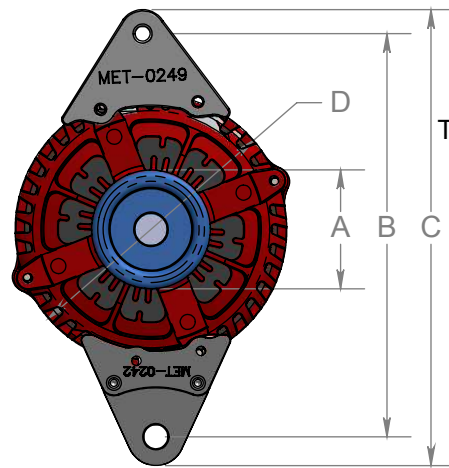

AT-SF-200-XX

AT-DF-200-XX

AT-DF4-200-XX

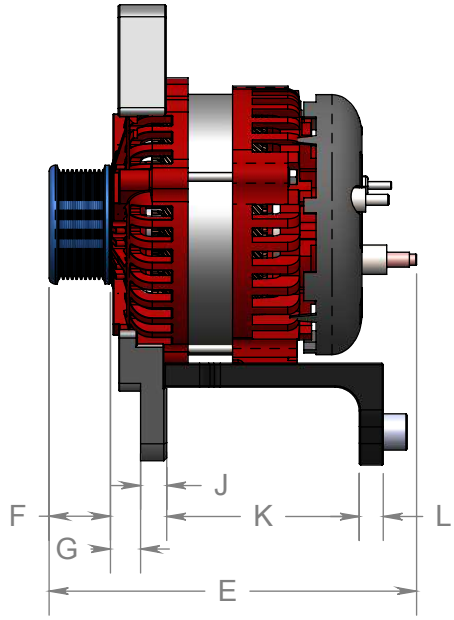
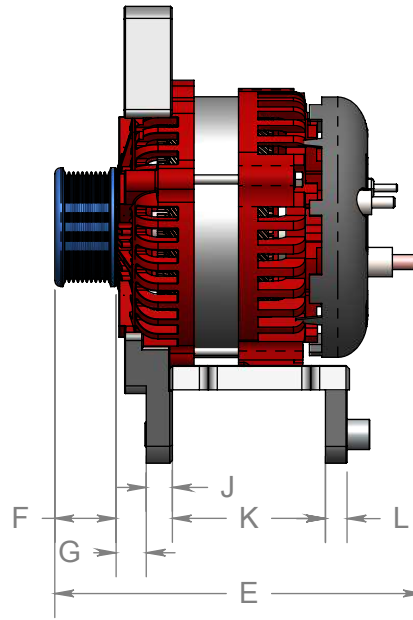
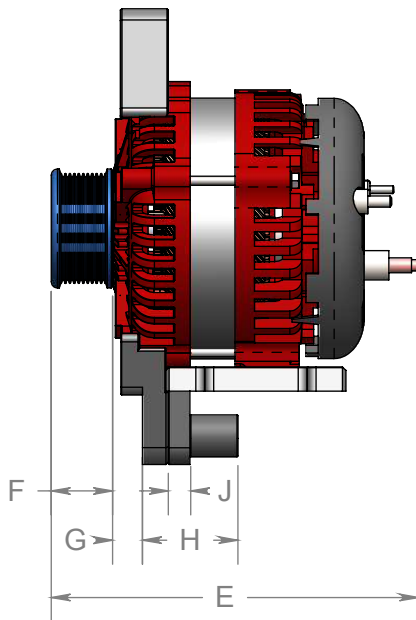

ITEM	DESCRIPTION	IN.	mm
A	Dual Vee (DV) Pulley Dia.	3.20	81
	K6 (Serpentine) Pulley Dia.	3.00	76
	J10 (Serpentine) Pulley Dia.	2.47	62
B	Mounting Hole-to-Hole	8.40	213
C	Over-all Height	9.50	241
D	Case Diameter	5.66	148
E	Over-all Length w/ DV Pulley	6.70	170
	Over-all Length w/ K6 Pulley	6.40	163
	Over-all Length w/ J10 Pulley	6.35	161
F	DV Pulley Width	1.49	38
	K6 Pulley Width	1.18	30
	J10 Pulley Width	1.14	29

ITEM	DESCRIPTION	IN.	mm
G	Case Front to Foot Front	.60	15
H	Foot Thickness (w/o spacer)	1.00	25
	Foot Thickness (w/ spacer)	2.00	51
I	Foot to Stator Output	3.44	87
J	Foot Thickness	.50	13
K	DF Saddle Width	3.18	81
	DF4 Saddle Width	4.00	102
L	Rear Foot Thickness	.50	13
M	DF Rear Foot to Stator Output	1.25	32
	DF4 Rear Foot to Stator Output	.375	10

Dimensions are approximate and for reference only. Contact Balmar Technical Support if further details are required.