

BALMAR 95-SERIES ALTERNATOR DATA SHEET

REVISED 05/15/09

Balmar's 95-Series, large case alternators deliver the size and charging output required to support battery banks of up to 800 amp hours at 12 volts or 400 amp hours at 24 volts. These 12-volt and 24-volt alternators are engineered for use with external multi-stage voltage regulation, making it possible to tailor charging voltage to maximize safety and efficiency when replenishing a wide variety of battery types.

A robust J180 saddle-style dual foot mounting configuration is ideal as a replacement for standard J180 mount alternators or for use as a second alternator on custom J180 saddle mount brackets. Isolated grounding termination provides sure continuity to system ground. High amperage diodes and extra-large sealed bearings ensure dependability and long alternator life.

Included in the 95-Series alternator family are: 150-amp/12-volt; 165-amp/12-volt; 210-amp/12-volt; and 140-amp/24-volt models. All models meet U.S. Coast Guard Title 33 standards for ignition protection.



SPECIFICATIONS

ALTERNATOR STYLE: Large-case

REGULATION: External P-type

CASE CONSTRUCTION: Cast aluminum

FINISH: White powdercoating

COOLING: Bi-directional external fan

DIODES: 6-positive, 6-negative; 50A/200V

MINIMUM REQUIRED BELT CONFIGURATION: Dual 1/2" vee; 8-groove serpentine

GROUND TERMINATION: Case independent

TACH OUTPUT: Unrectified AC stator output

BEARINGS: Sealed ball bearing. Heavy duty radial (front). Heavy duty needle (rear)

TENSIONING ARM: 180° offset from mounting foot

AVAILABLE OUTPUTS: 165A/12V, 210A/12V, 140A/24V

MOUNTING STYLE: 4" I.D. saddle mount (J180-style).

IGNITION PROTECTION STANDARDS: USCG TITLE 33

OUTPUT CURVES - 150A & 165A (12-VOLT MODELS)

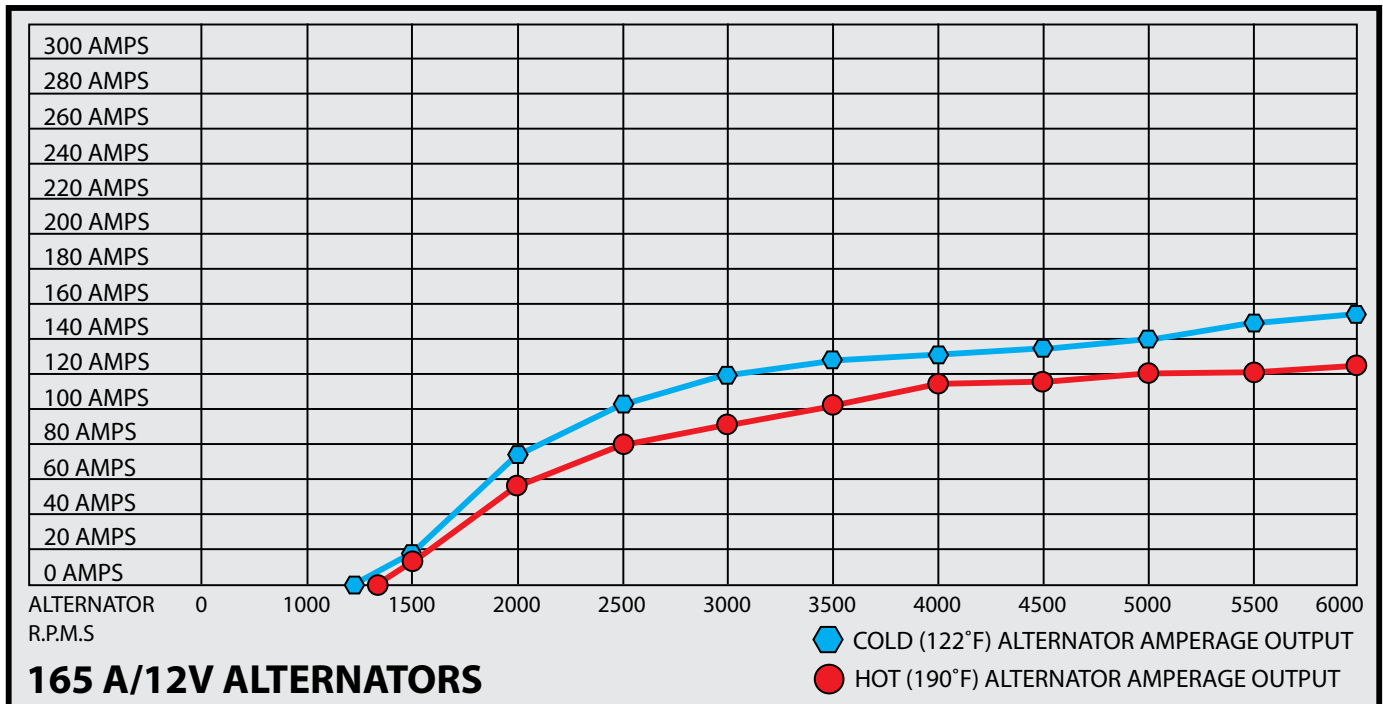
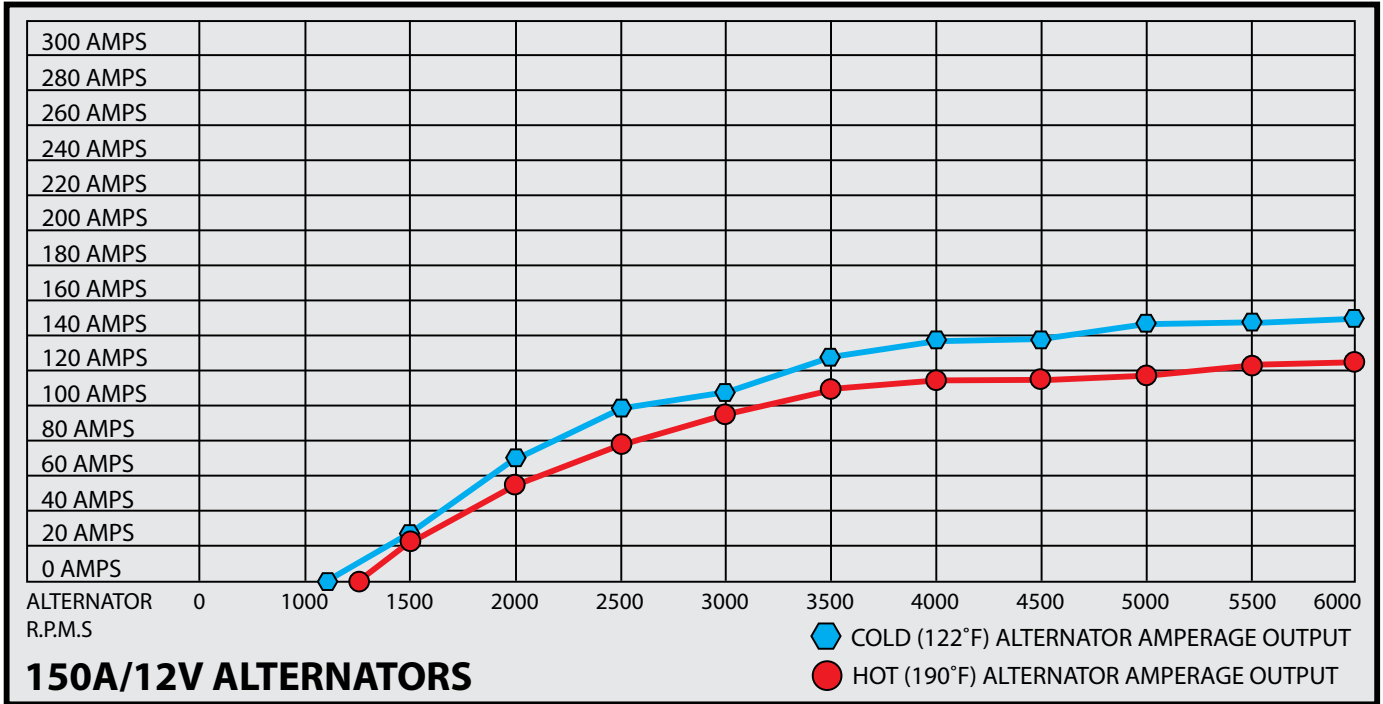

PLEASE NOTE: Measurements provided are believed to be correct at the time of publication. Diagrams shown are for illustrative purposes and are not designed to be used for engineering. Please contact our Customer or Technical Services departments or see our 2009 Product Guide for additional information.

OUTPUT CURVES - 210A (12-VOLT MODEL)

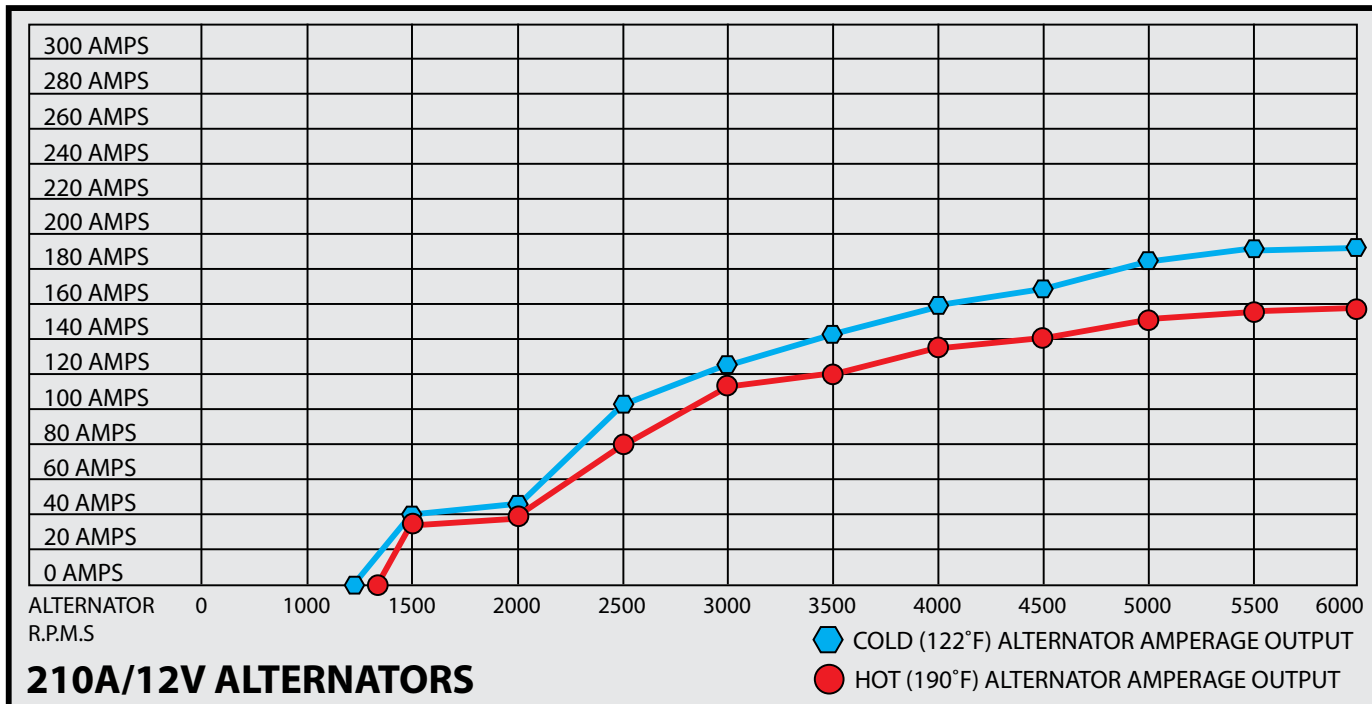

OUTPUT CURVES - 140A (24-VOLT MODEL)

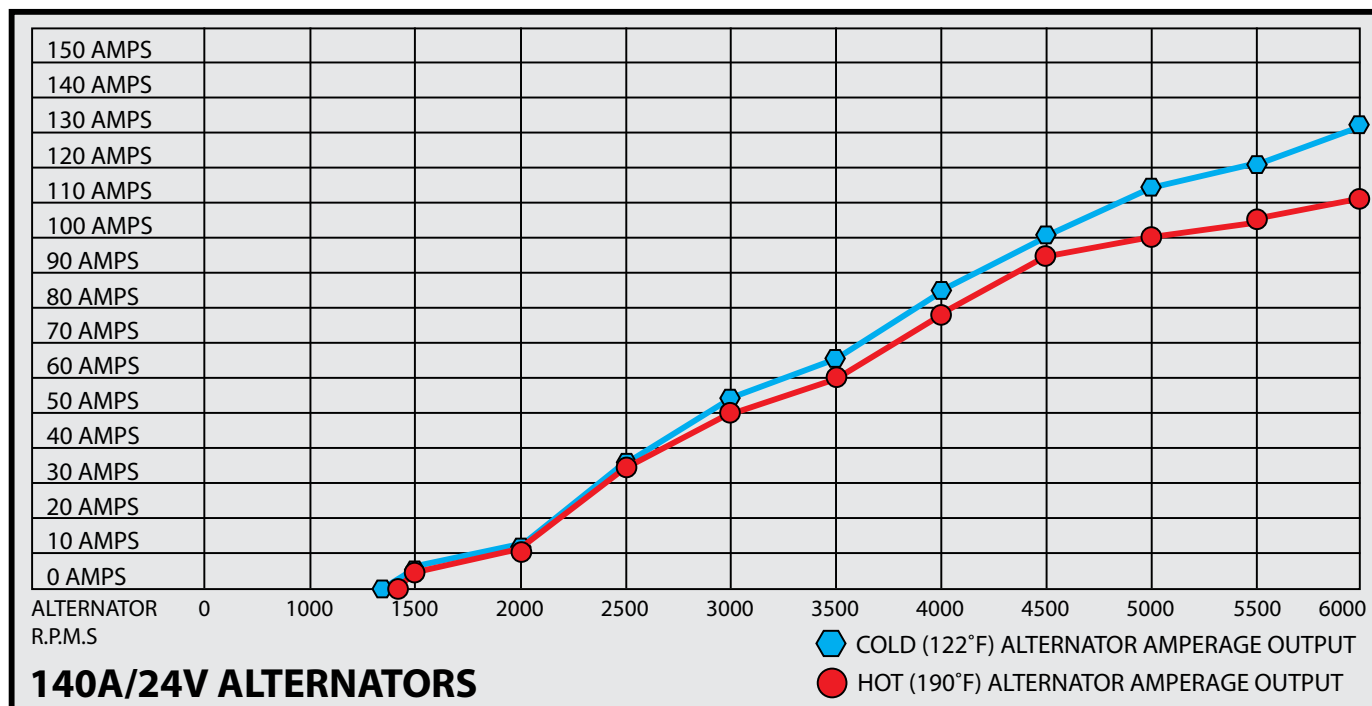

PLEASE NOTE: Measurements provided are believed to be correct at the time of publication. Diagrams shown are for illustrative purposes and are not designed to be used for engineering. Please contact our Customer or Technical Services departments or see our 2009 Product Guide for additional information.

ALTERNATOR DIMENSIONS

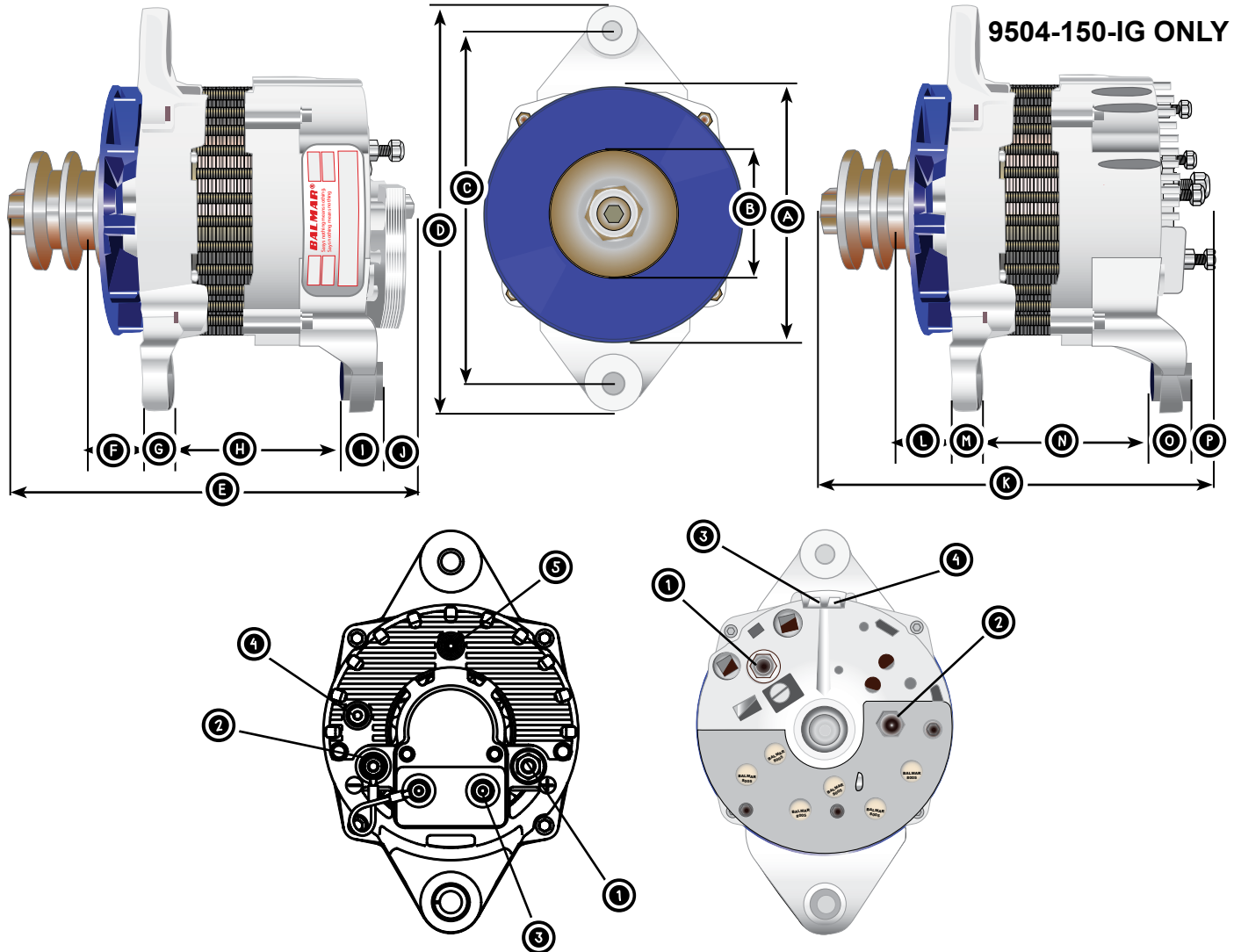

ITEM	DESCRIPTION	IN.	MM
A	Case Diameter	6.0	152.4
B	Std. Pulley Diameter	2.9	73.7
C	Bolt-to-Bolt Center	7.7	195.5
D	Overall Height	9.0	228.6
E	Overall Length	8.7	220.9
F	Sheave center to front foot	1.1	27.9
G	Front Foot Width	.56	14.2
H	Inside front to rear foot	4.1	104.1
I	Rear foot (including spacer)	.75	19.0
J	Mounting foot aft of alternator	.75	19.0
K	Overall length (150A only)	1.0	25.4
L	Sheave center to front foot	1.1	27.9
M	Front Foot Width	.56	14.2
N	Inside front to rear foot	4.1	104.1
O	Rear foot (including spacer)	.75	19.0
P			
ADDITIONAL ALTERNATOR MEASUREMENTS			

		Dimension
Mounting Foot Bore		1/2" / 12.7mm
Tensioning Arm Bore		5/16" / 7.9mm
Positive Output Post		
Field Input Post		
Ground Post		
Stator/Tach Output Post		
TERMINAL CONNECTION LOCATIONS		
1	Positive Output Terminal	
2	Ground Terminal	
3	Field Input Terminal	
4	Stator/Tach Output Terminal	
5	D+ (Lamp) Terminal	

PLEASE NOTE: Measurements provided are believed to be correct at the time of publication. Diagrams shown are for illustrative purposes and are not designed to be used for engineering. Please contact our Customer or Technical Services departments or see our 2009 Product Guide for additional information.